

TEMPERATURE CONTROL STEAM TRAP

TB1N

USER'S MANUAL

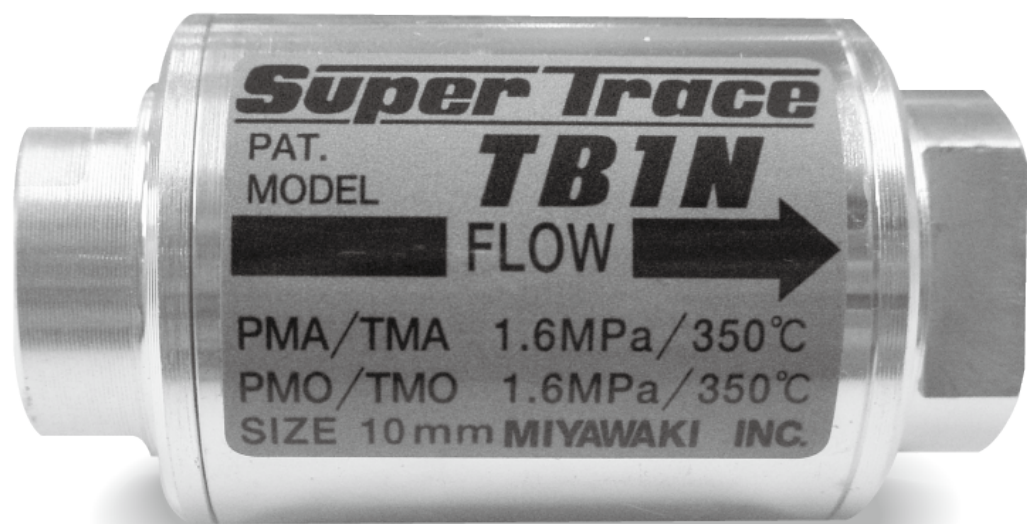

 **MIYAWAKI INC.**

SAFETY GUIDE

The model Supertrace TB1N trap is an energy saving, copper trace, temperature control steam trap that takes advantage of the sensible heat in a condensate by discharging condensate that is lower than the saturated temperature, for any arbitrary temperature setting. Please use this product in a steam trace line or as instrumentation.

In order to get maximum benefit from this product, be sure to read this manual before installing it.

The following warnings and cautions are shown at appropriate places in this manual.



Failure to observe this type of precaution may lead to serious injury or death.



Failure to follow this type of precaution can lead to injury or damage to equipment and property.

Table of Contents

1	SPECIFICATIONS AND MARKINGS	1
2	CONSTRUCTION DETAILS	2
3	INSTALLATION	3
4	SETTING THE TEMPERATURE	4
5	STROKE TABLE	5
6	MAINTENANCE	6
7	TROUBLESHOOTING	9
8	WARRANTY	10
9	SERIAL NUMBER(S.No.) DESIGNATION	11
10	GUIDANCE FOR READING SPECIAL PRODUCT NAME	12

1 SPECIFICATIONS AND MARKINGS



WARNING

Be sure not to use this product at higher pressures than the specified maximum allowable pressure (PMA) or at temperatures higher than the specified maximum allowable temperature (TMA).

The following items are displayed on the name label or the side of the product.

Check each item to avoid misuse of the product.

- 1) Maximum allowable pressure (PMA): 1.6MPa (230psig)
 - 2) Maximum allowable temperature (TMA): 350°C (662°F)
 - 3) Maximum Operating pressure (PMO): 1.6MPa (230psig)
 - 4) Maximum operating temperature (TMO): 350°C (662°F)
 - 5) Size: 8 mm (1/4"), or 10 mm (3/8")
 - 6) Year of production: The two leftmost digits in the four-digit or nine-digit 'S No.' on the name plate are the last two digits of the year of production.
 - 7) Flow direction: Shown by an arrow
 - 8) Model symbol: Showing the product model name
- Some pictures and illustrations in this manual are that of the representative model of TB1N models. For more details regarding dimensions and other specifications, please refer to the catalog.

2 CONSTRUCTION DETAILS

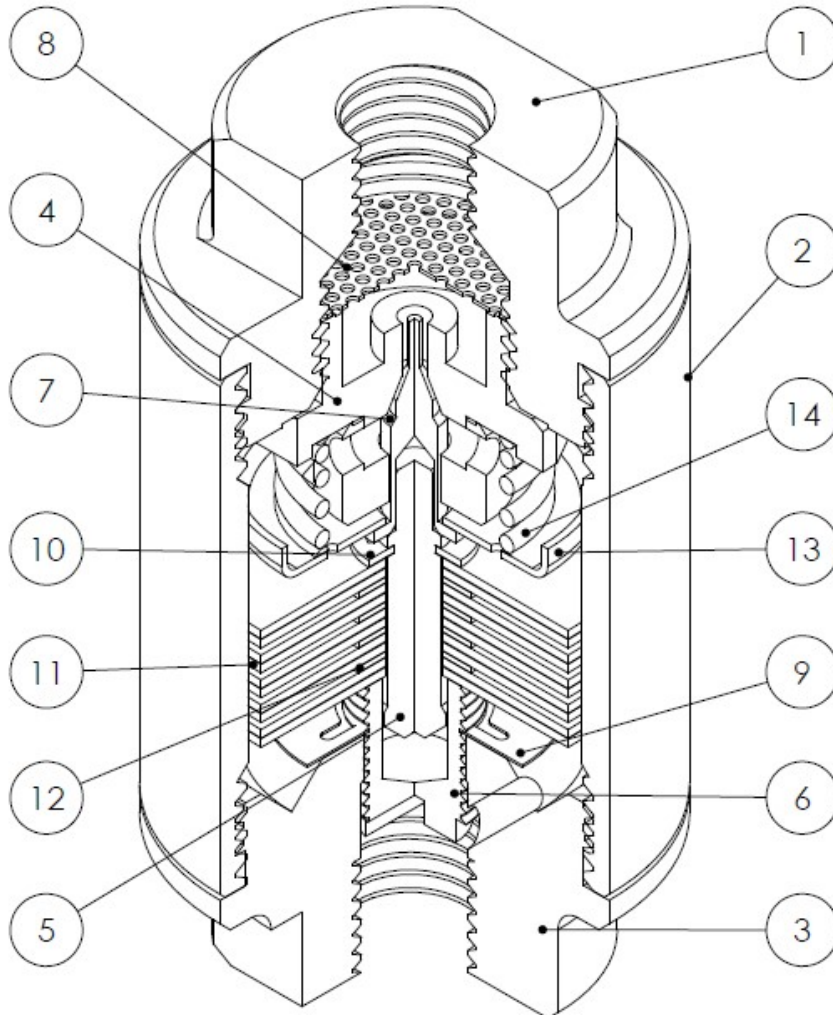

-
- | | | |
|---------------|----------------|------------------|
| 1. Body | 6. Adjust Bolt | 11. Bimetal |
| 2. Bonnet | 7. Valve | 12. Washer |
| 3. Cover | 8. Screen | 13. Spring Plate |
| 4. Valve Seat | 9. Washer | 14. Spring |
| 5. Shaft | 10. E-ring | |

3 INSTALLATION



WARNING

Pay very careful attention when working in hazardous environments. There is a risk of explosion and the possibility of dangerous gases leaking. Always check whether the pipeline contains flammable, high pressure or high temperature materials before starting to work.

- **Make sure that isolation valves are installed on both the upstream and downstream lines.**



CAUTION

Before installing the product, open both isolation valves and the bypass valve, if one exists, to blow out any debris or dirt inside the pipeline. After blowing out the line, before starting to work, close the isolation valves and allow time for the temperature to drop to a safe working temperature.

When installing the product, be sure to leave clearance for maintaining it.

- 1) Remove the dustproof seals covering both connections.
- 2) Check the flow direction indicated on the side of the body.
- 3) The TB1N can be used for both horizontal and vertical lines.
- 4) Open the isolation valve on the upstream line and make sure the product works normally.
- 5) When using as a trace line, install a trap in a trace pipe.

4 SETTING THE TEMPERATURE



WARNING

Only set the temperature when the bimetals in the body are flat, before any steam is flowing. Be sure not to set the temperature while the steam is flowing because the steam or condensate may spurt out around the edges in the setting part.

4.1 Set temperature

The set temperature is the temperature at which condensate will be discharged from the temperature control trap. It is set to the temperature specified by the customer when shipped. If the customer doesn't specify a temperature, it is always set to 70°C at a pressure of 0.5 MPa, as the factory default setting.

4.2 Setting the temperature

- 1) When the bimetal (11) is resting flat, screw the adjust bolt (6) slowly clockwise until it stops. This position is the starting point to set the temperature.
- 2) See the stroke table in Section 5 to find the number of turns corresponding to the temperature you want.
- 3) Screw the adjust bolt (6) counterclockwise the number of turns specified in the table.

4.3 Precautions for setting the temperature

Steam trace

Basically, the set temperature should be the temperature used to control the objects being heated. However, please make sure to consult us if you will use the product in a cold climate.

Other equipment

Since the appropriate set temperature depends on the equipment, please consult us.

5 STROKE TABLE

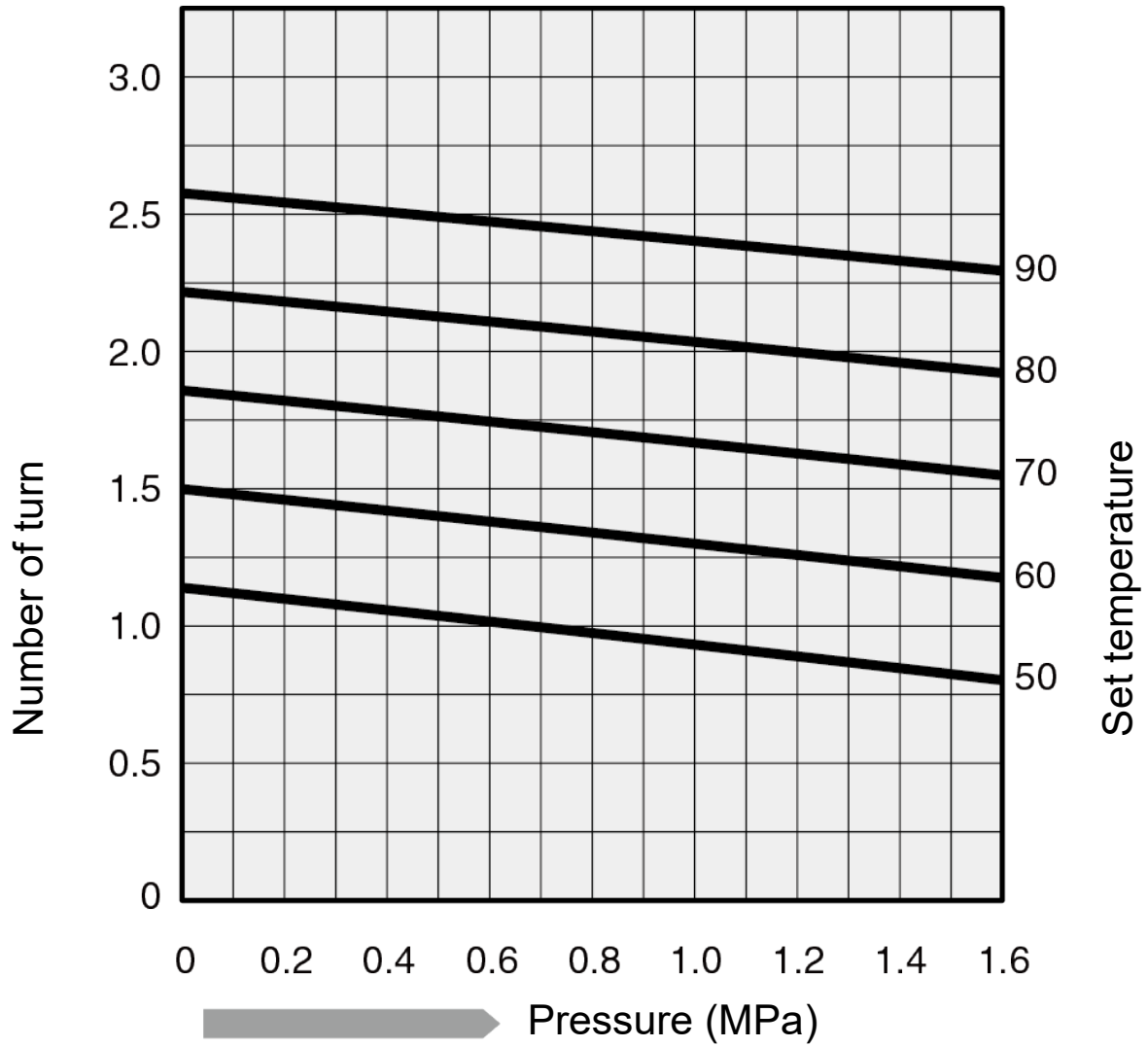

6 MAINTENANCE



WARNING

- Before removing the trap from the pipe or disassembling it, be sure to close the isolation valves. Then, release the residual pressure from the trap body (make sure that the pressure in the main body is equal to the atmospheric pressure). After it has fully cooled down (after the temperature of the main body has reached ambient temperature), confirm for safe conditions and then begin work.
- Even when the isolation valves are closed, there may be residual internal pressure due to leaks from the isolation valves. Therefore, be very careful.



CAUTION

- When replacing parts, make sure the replacement parts are supplied by Miyawaki.

The performance of steam traps deteriorates gradually over time due to wear, corrosion or dirt accumulating around the valve and the valve seat. Please conduct periodic diagnosis of traps in order to keep steam control systems and equipment working well.

6.1 Tools for Diagnosis Steam Traps

■ Dr. Trap

It is a diagnostic tool with hardware (diagnostic equipment) that performs automatic diagnosis at high speed (maximum 10 seconds) and exclusive aggregate analysis software from the vibration and temperature information of the trap.

Diagnostic information is recorded in the diagnostic equipment and data can be transferred to the software. As a result, high-speed aggregate analysis, quantitative grasp of steam leakage and loss amount are possible.

■ Dr. Trap Jr.

It is an inexpensive and simple diagnostic tool using hardware (steam trap checker) with vibration sensor, temperature sensor and exclusive aggregate analysis software.

From the vibration and temperature information of the trap, the judgment such as good or fail is made by a diagnostician. By inputting the vibration value detected by the steam trap checker to the aggregate analysis software, it is possible to quantitatively grasp the amount of steam leakage and money loss.

Caution:

Even if both diagnostic tools are used, accurate diagnosis results may not be obtained depending on the location and installation status of the steam trap, or the type and operating condition of the steam trap.

For details, please contact MIYAWAKI, our local authorized agent, or the place where you purchased.

6.2 Repairs

When a trap fails, it is necessary to clean the internal parts and to replace damaged parts. Take the failed trap apart following the steps below.

6.2.1 Disassembling the trap

- 1) Secure the body (1) (or cover (3)) in a vise, and remove the cover (3) (or the body (1)). When the cover (3) and the adjust bolt (6) are removed as a unit without disassembling them, it will not be necessary to readjust the temperature setting after reassembly.
- 2) Remove the bimetal part (the bimetal (11), the shaft (5), the E-ring (10), and the washer (12)), the valve (7), the spring plate (13), and the spring (14) by hand.
*Do not take apart the bimetal part. If the bimetal discs come off the bimetal part, each disc has a mark on one face. Place the two marked surfaces facing out, away from each other, and then put the two bimetal discs with the washer in between them back into the bimetal part. Treat the two bimetal discs as a set. If this assembly is wrong, the bimetal part will not function properly.
- 3) When removing the bonnet (2) from the body (1) or the cover (3), be careful to keep the bonnet (2) from being deformed or distorted. Use the proper tools to remove the parts.
- 4) Remove the valve seat (4) using a socket wrench.
- 5) Clean and inspect the parts thoroughly.

After repairing the trap, re-assemble the parts in reverse order as follows.

6.2.2 Reassembling the trap

- 1) Insert the screen (8) into the body (1) and screw the valve seat (4) into the body (1).
- 2) Reinstall the spring (14) and the spring plate (13) on the valve seat.
- 3) Put the valve (7) into the center hole in the spring plate (13), and place it on the spring plate (13) so that the tip of the valve (7) can be inserted into the hole in the valve seat (4).
- 4) Reinstall the bimetal part so that the tip of the shaft (5) fits into the hole in the valve (7).
- 5) Screw the bonnet (2) onto the body (1), and the cover (3) onto the bonnet (2). Then, tighten the cover (3).

* The proper torque for the Body (1), cover (3), and valve seat (4) are as shown in the following table.

Parts	Tools	Across the flats	Torque
Body (1)	Torque wrench	22 mm (0.86")	56N·m
Cover (3)	Torque wrench	22 mm (0.86")	56N·m
Valve seat (4)	Torque wrench	23 mm (0.91")	56N·m

* When the adjustment unit is disassembled, after reassembling it set the temperature again, following the steps shown in the Section 4, "Setting the temperature".

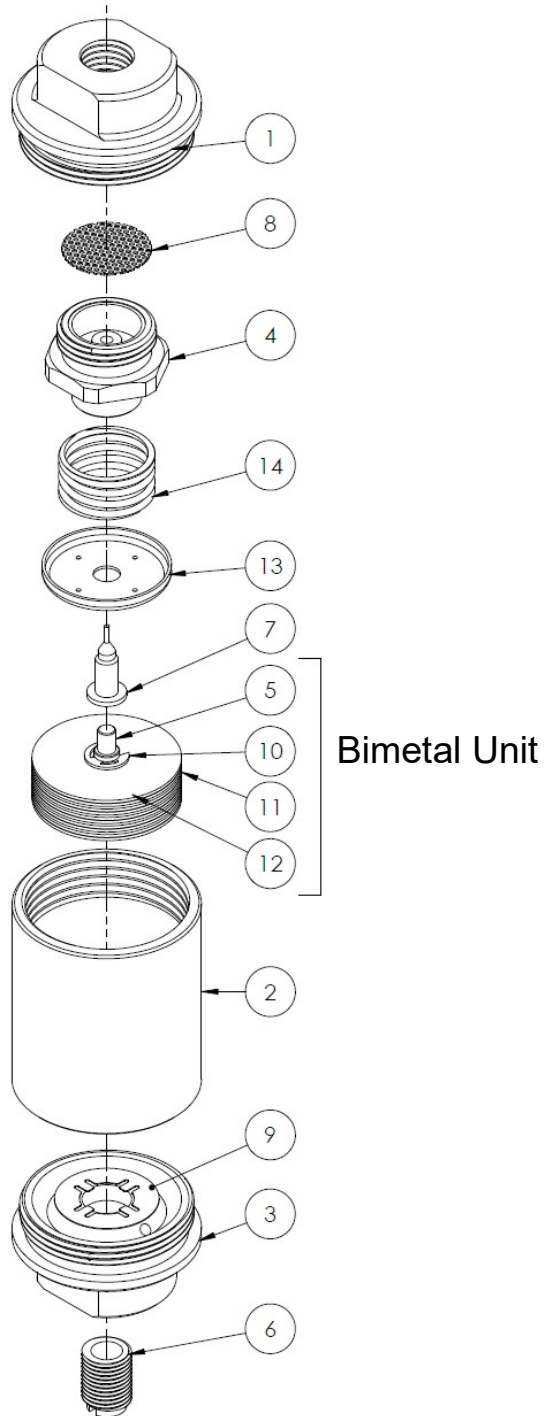

- 1. Body
- 2. Bonnet
- 3. Cover
- 4. Valve Seat
- 5. Shaft

- 6. Adjust Bolt
- 7. Valve
- 8. Screen
- 9. Washer
- 10. E-ring

- 11. Bimetal
- 12. Washer
- 13. Spring Plate
- 14. Spring

7 TROUBLESHOOTING

Problem		Possible cause	Solution
Steam leaks or blows through.		Dirt is stuck around the valve (7) or valve seat (4)	Clean the valve (7) and the valve seat (4).
		The valve seat (4) is loose.	Tighten the valve seat (4). *1
		Damage, erosion or corrosion of the valve (7) or valve seat (4)	Replace the valve (7) and the valve seat (4) as a set.
		The bimetal (11) is damaged.	Replace the bimetal unit.
		The adjust bolt (6) is backed out too far. (Improper set temp.)	Set the temperature again.
Steam leaks from the body.	From the connection between the body and cover	The body (1) is loose.	Tighten the body (1). *2
		The cover (3) is loose.	Tighten the cover (3). *3
Insufficient condensate discharged, or no condensate discharged.		The screen (8) is clogged.	Clean the screen (8).
		Dirt has built up on or around the valve seat (4).	Clean the valve seat (4).
		Dirt accumulated in the fluid passage of the body (1)	Clean the body (1).
		The bimetal (11) is damaged.	Replace the bimetal unit.
		The adjust bolt (6) is too tight. (Improper set temp.)	Set the temperature again.
		Wrong installation direction	Reinstall the product in the correct direction.
		Insufficient condensate capacity.	Replace the trap with a larger capacity trap.

*1, *2 and *3: Refer to the torque tables in Section 6, "Maintenance" to retighten the parts to the correct torque.

8 WARRANTY

8.1 Warranty period

The warranty period is 18 months after shipment or 12 months after installation, whichever occurs first.

8.2 Details of the warranty

If the product stops working correctly within the warranty period, we will repair or replace the product free of charge if the cause of the trouble is not one of the following items.

- 1) The precautions described in this manual were not observed.
- 2) User's errors or mistakes such as an inappropriate installation or incorrect handling, or an excessively large impact caused by dropping
- 3) Problems caused by devices or equipment other than ours, or a disallowed use environment
- 4) When a repair or modification has been performed by anyone other than us or people who are authorized to make such repairs
- 5) Intrusion of salt or other substances that promote significant rust or corrosion or problems from fluids that contain the same substances
- 6) Consumable parts such as Packing, Gasket, O-ring, Diaphragm, etc
- 7) Attachment or accumulation of foreign matter in the pipe, such as dust and scale
- 8) Problems from fires, natural disasters, or other force majeure which is not our responsibility

8.3 Warranty limitation

The remedy available under the warranty shall not exceed the sales price of the products delivered, for any cause whatsoever.

9 SERIAL NUMBER (S. No.) DESIGNATION

The following 4-digit or 9-digit “S.No.” is displayed on the product.

- For 4-digit display

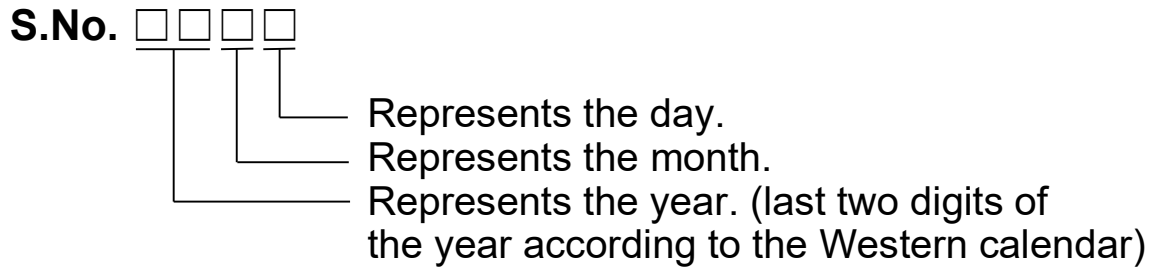

Example of serial number designation

1 7 1 1 → Jan.1, 2017

2 9 X M → Oct. 21, 2029

- For 9-digit display

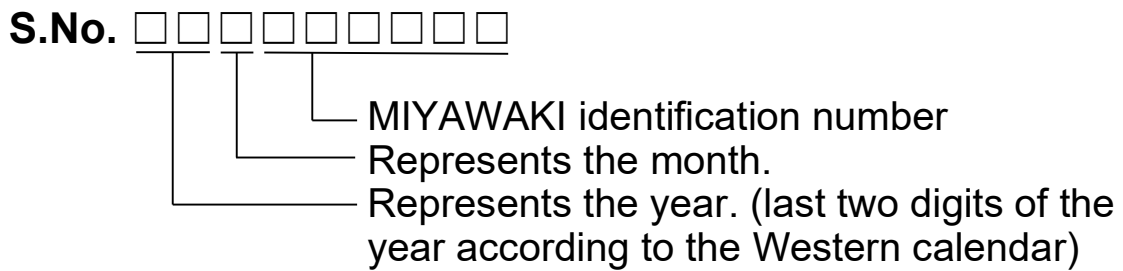

Example of serial number designation

1 7 1 1 2 C 0 2 0 → Jan., 2017

2 9 X 0 5 M 0 5 0 → Oct., 2029

Month designation system

Month	1	2	3	4	5	6	7	8	9	10	11	12
Symbol	1	2	3	4	5	6	7	8	9	X	Y	Z

Day designation system

Day	1	2	3	4	5	6	7	8	9	10	11	12
Symbol	D	E	F	G	H	J	K	L	M	N	O	P

Day	13	14	15	16	17	18	19	20	21	22	23	24
Symbol	D	E	F	G	H	J	K	L	M	N	O	P

Day	25	26	27	28	29	30	31
Symbol	Q	R	S	T	U	V	W

10 GUIDANCE FOR READING SPECIAL PRODUCT NAME

○○○-○○-□

Special symbol:
Symbol apply only to special product
(Please refer to table 1 for details)
 English letter after “-“

Model symbol:
Product model number

Table 1 Symbol description

Suffix	Special contents
A	Trap for high-pressure gas installed property (only for Gas Trap)
C	Blow valve attached
K	Change of gasket
L	Special face to face dimension
M	Change of parts material
P, T	Change of operating pressure, temperature, condensate capacity, etc
R	Change of screen mesh
V	Change of air vent
X	Other than mentioned above or complex of special contents above

For any questions about the product that you purchased or about the details in this user's manual, please contact the following.

- © 2023 MIYAWAKI INC.

This user's manual may not be reproduced or copied in whole or in part, without the written consent of MIYAWAKI INC.

- Some special specifications of the product you have, may found to be different from the ones in the user's manual. If you have any question, please contact MIYAWAKI, our local authorized agent, or the company where you purchased the product.
-



If you need any assistance regarding this manual, please contact MIYAWAKI INC.'s International Sales Dept. or its local representative. By scanning QR Code, you can access inquiry form.



INTERNATIONAL SALES DEPT.
2-1-30, Tagawakita, Yodogawa-ku, Osaka, 532-0021, Japan
Tel: +81-6-6302-5549
www.miyawaki-inc.com/en e-mail: export@miyawaki-inc.co.jp

EU Importer and Authorized representative:



Birnbaumsmühle 65, 15234 Frankfurt (Oder), Germany
Tel: +49-335-4007-0097
www.miyawaki.de e-mail: info@miyawaki.de

China Importer and Authorized representative:



Room902, Building 8, Huaqing Chuangzhi Park, No.3 Qingyan Road, Huishan District,
Wuxi City Jiangsu Province China
Tel: +86-510-8359-5125
www.miyawaki-inc.com.cn e-mail: mywkwest@miyawaki-inc.com.cn

808030-05 2311

TB1N