

OPERATION MANUAL  
FOR  
DIRECT-ACTING PRESSURE REDUCING VALVE  
MODEL:RE2 SERIES

# SAFETY GUIDE

In order to get maximum benefit from this product, be sure to read this manual before installing it.

The following warnings and cautions are shown at appropriate places in this manual.



**Warning**

Failure to observe this type of precaution may lead to serious injury or death.



**Caution**

Failure to follow this type of precaution can lead to injury or damage to equipment and property.

## Contents

---

1. Purpose of use	1
2. Specifications	1
3. Construction details	2
4. Precautions for piping	3
5. Pressure adjustment procedure	4
6. Troubleshooting	5-6
7. Maintenance	7-8
8. Warranty	9
9. Serial number (S.No.) designation	10
10. Guidance for reading special product name	11

## 1. Purpose of use

The type RE2 is a compact and lightweight direct-acting pressure reducing valve for steam that employs MIYAWAKI's proprietary micro-bellows.

It is most suitable for small steam equipment and steam irons in, for example, the sawing and laundering industries.

## 2. Specifications

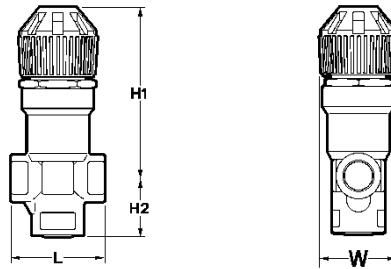

Model	Connection		Operating pressure range (Primary pressure) (MPa)	Control pressure range (Secondary pressure) (MPa)	Maximum pressure-reducing ratio	Maximum operating temperature (°C)	Body material	Material of principal parts	Dimensions (mm)				Weight (kg)
	Type	Nominal dia. (A)							L	H1	H2	W	
RE2	Threaded	10	0.2~1.0	0.1~0.5	10:1	184	Brass	SUS	50	89	31	42	0.56

### Specification of accessory strainer

Model	Connection		Maximum operating pressure (MPa)	Maximum operating temperature (°C)	Material		Screen Mesh	Face-to-face dimension (mm)	Weight (kg)
	Type	Nominal dia. (A)			Body	Screen			
YBS	Threaded	10	1.0	200	Bronze	Stainless steel	100	65	0.2

### 3. Construction details

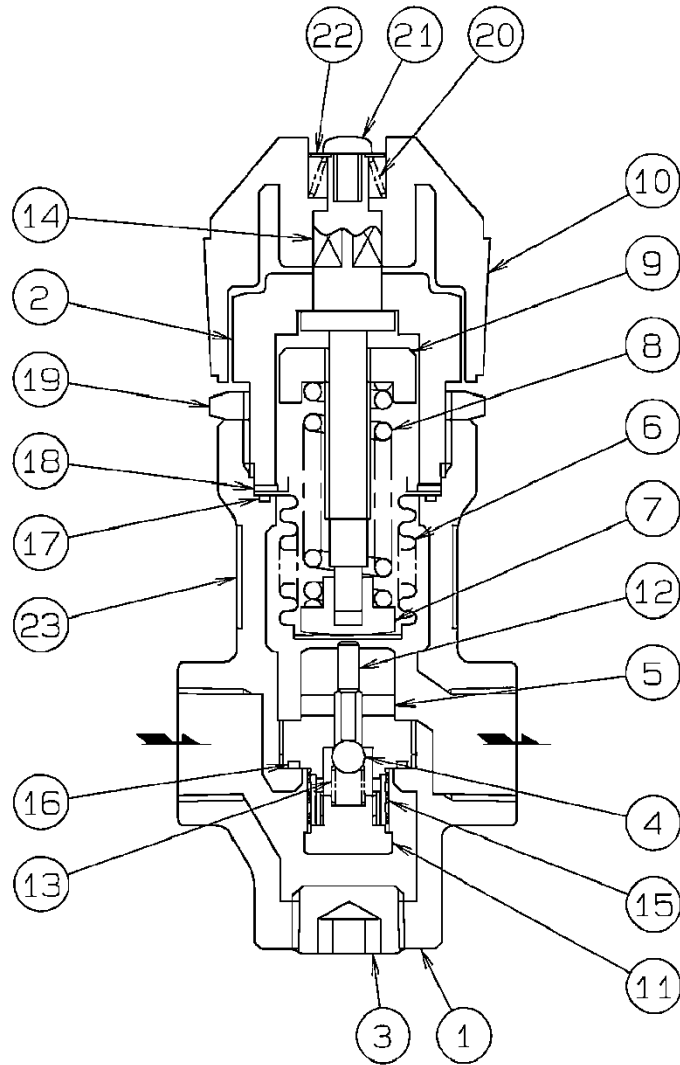

- |                |                  |                |
|----------------|------------------|----------------|
| 1. Body        | 9. Sleeve        | 17. Gasket     |
| 2. Cover       | 10. Handle       | 18. Gasket     |
| 3. Plug        | 11. Seat bushing | 19. Lock nut   |
| 4. Valve       | 12. Shaft        | 20. Spring     |
| 5. Valve seat  | 13. Spring       | 21. Screw      |
| 6. Bellows     | 14. Adjust bolt  | 22. Washer     |
| 7. Spring stay | 15. Screen       | 23. Name plate |
| 8. Spring      | 16. Gasket       |                |

## 4. Precautions for piping



### Caution

Before installing the product, open both isolation valves and the bypass valve, if one exists, to blow out any debris or dirt inside the pipeline.

- 1) Take care to prevent the condensate from entering the pressure reducing valve. If condensate flows into the pressure reducing valve, it can cause hunting and other phenomena and may damage the sealing surface of the valve and valve seat, as well as the sliding section. If condensate is expected to flow in the pressure reducing valve, install a separator, steam trap, or others on the inlet side of the pressure reducing valve to prevent flow of condensate as much as possible.
- 2) Take care to prevent rust, scale, and other foreign substances from flowing in the pressure reducing valve.  
Flow of a foreign substance in the pressure reducing valve can cause leakage (increase in the secondary pressure) and other problems.  
In order to keep foreign substances out, install the ancillary strainer (100 mesh) on the inlet side of the pressure reducing valve. Install the strainer in a lateral direction (in the case of horizontal piping) to prevent the stagnation of condensate.  
Remove initial low-temperature condensate and foreign substances from the piping by blowing the pipes before passing steam through the pressure reducing valve.
- 3) When a manual valve, solenoid valve, or other valves on the outlet side of the pressure reducing valve are kept closed (dead-end service), install a steam trap between the pressure reducing valve and the outlet valve to prevent water hammer and abnormal operation (increase in the secondary pressure) of the pressure reducing valve.
- 4) Make the straight section of the piping upstream and downstream of the pressure reducing valve as long as possible (more than ten times of the pipe diameter is recommended).
- 5) Avoid piping that is drastically narrowed upstream or downstream of the pressure reducing valve to prevent pressure drop as much as possible.
- 6) Install a safety valve on the secondary side of the pressure reducing valve for safety and to prevent damage of equipment and devices.  
If a safety valve cannot be installed, use equipment or devices which have withstand pressure more than equal to the primary pressure.
- 7) When the pressure reducing valve is not used for a long time, remove condensate from the piping completely.

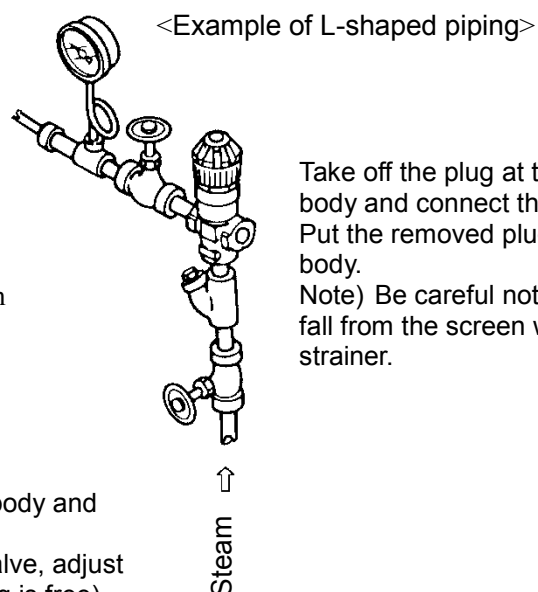
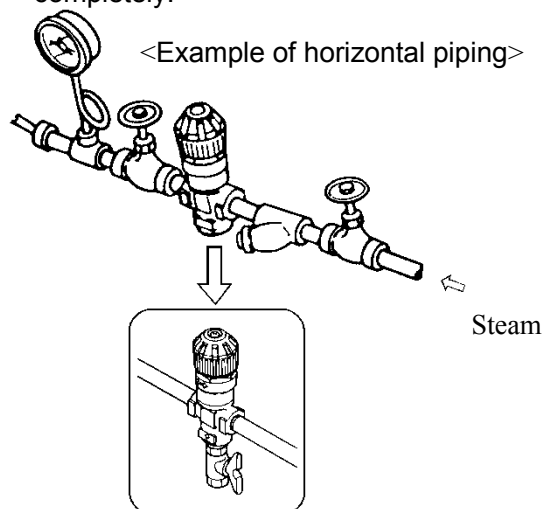

Take off the plug at the bottom of the body and connect the inlet pipe. Put the removed plug to the inlet of the body.  
Note) Be careful not to let dust or scale fall from the screen when checking the strainer.

You can take off the plug at the bottom of the body and install a blowdown valve or a steam trap.

Note) Before blowing the pressure reducing valve, adjust its handle to the zero point (the adjusting spring is free) and close the stop valve on the outlet side.

## 5. Pressure adjustment procedure

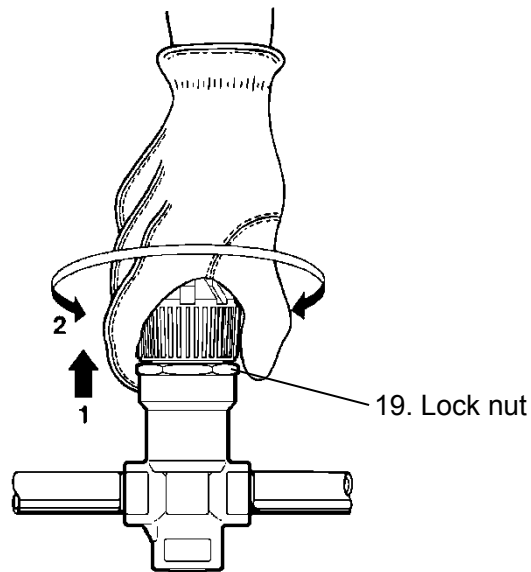

- 1) Blow off low temperature condensate and foreign substances in the piping before flowing steam in the pressure reducing valve.
- 2) Make sure that the stop valves upstream and downstream of the pressure reducing valve are completely closed.
- 3) Pull the handle up gently and turn it to the right (direction of arrow L) to free the adjust spring. (When the spring is free, the handle can be turned very lightly.)
- 4) Firstly open the secondary stop valve slightly, then open the primary stop valve slowly until it is fully open.
- 5) Pull the handle up gently and slowly turn it to the left (direction of arrow H) to the specified pressure while monitoring the pressure gauge.
- 6) When you release the handle, it is locked.
- 7) Open the secondary stop valve fully.

Note) - Be sure to wear gloves when you adjust the pressure.

- The lock nut (19) secures the cover (2), so do not touch it unless you disassemble the pressure reducing valve.

## 6. Troubleshooting

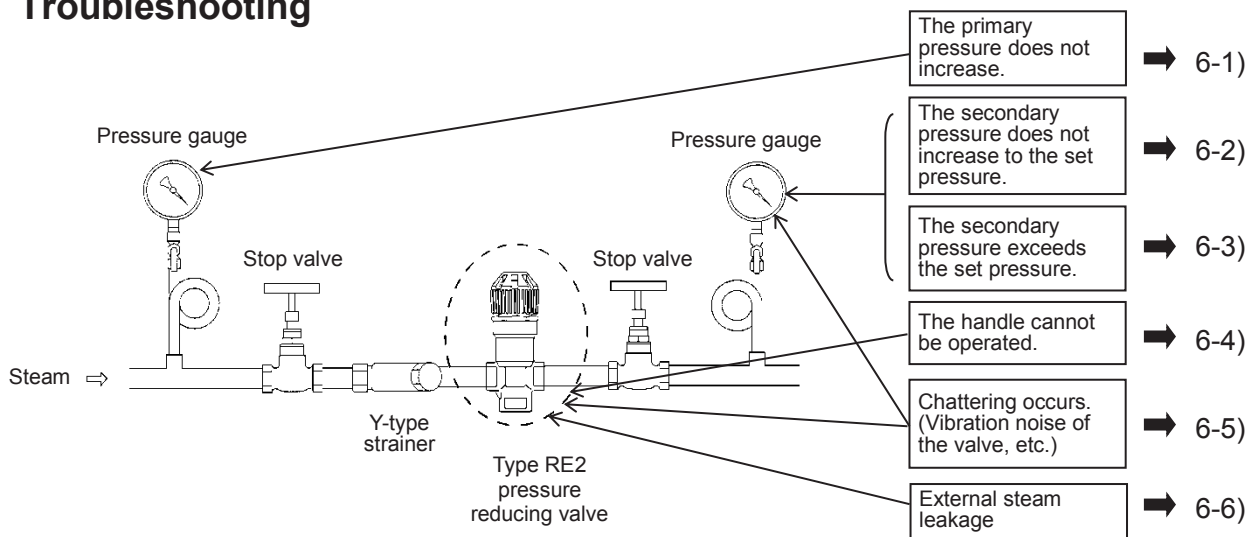

### 6-1) Phenomenon: The primary pressure does not increase.

	Cause of the problem	Action
Related to piping	Shortage of steam volume supplied to the primary side. (The capacity of the boiler may be insufficient.)	1) Recheck the steam volume. 2) Reconsider the system.
	The steam source valve is closed.	Open the steam source valve.
	The pipe on the primary side is too small.	Review the pipe size.

### 6-2) Phenomenon: The secondary pressure does not increase to the set pressure.

	Cause of the problem	Action
Due to piping	Incorrect pressure setting.	Turn the handle (10) for re-adjustment.
	Insufficient pressure reducing valve capacity	Re-select pressure reducing valve with the proper capacity.
	Clogging in the inlet side strainer.	Disassemble and clean the strainer.
	The secondary side stop valve is closed.	Open the stop valve.
	The pipe on the secondary side is too small.	Review the pipe size.
Due to internal parts	Clogged screen (15).	Clean the screen (17). If it is damaged, replace it with a new one.
	Poor sliding of the shaft (12).	Clean the sliding section of the shaft (12) and the valve seat (5). If the sliding section is damaged, replace the valve unit with a new one.

**6-3) Phenomenon: The secondary side pressure increases beyond the set pressure.**

	Cause of the problem	Action
Due to piping	Incorrect pressure setting.	Turn the handle (10) for re-adjustment.
	The consumption on the secondary side is close to zero.	Install a trap on the secondary side of the pressure reducing valve.
	Wrong installation direction.	Install correctly according to the flow direction.
	Pressure gauge fault.	Replace the pressure gauge.
Due to internal parts	Pressure leaks past the valve (4) due to dirt and scale holding the valve open.	1) Push the screw (21) of the handle (10) using a Phillips-head screwdriver. (Refer to 7-2) 2) Clean the surfaces of the valve (4) and the valve seat (5). If either surface is damaged, replace the parts with new ones.
	Poor sliding of the shaft (12).	Clean the sliding section of the shaft (12) and the valve seat (5). If the sliding section is damaged, replace the valve unit with a new one.
	3) Damaged bellows (6).	Replace the bellows (6) with a new one.

**6-4) Phenomenon: The handle cannot be operated.**

	Cause of the problem	Action
Due to internal parts	Incorrect operation of the handle	Pull the handle (10) up gently and then turn it.
	The sleeve (9) and adjust bolt (14) have seized.	Replace the sleeve (9) and adjust bolt (14) with new ones.

**6-5) Phenomenon: The secondary pressure is unstable, and chattering occurs (vibration noise of the valve, etc.).**

	Cause of the problem	Action
Due to working condition	Condensate flows in from the primary side.	Install a trap on the primary side of the pressure reducing valve.
	Used below the minimum adjustable flow rate.	Re-select pressure reducing valve with the proper capacity.
Due to internal parts	Poor sliding of the shaft (12).	Clean the sliding section of the shaft (12) and the valve seat (5). If the sliding section is damaged, replace the valve unit with a new one.

**6-6) Phenomenon: Steam leaks out.**

	Cause of the problem	Action
Due to internal parts	Loose cover (2) and plug (3)	1) Tighten them to the specified torque. 2) Put the sealing tape to the screw part of the plug (3).
	The bellows gaskets (17) or cover gasket (18) is damaged.	Replace the gaskets (17) (18) with new ones.
	The bellows (6) is damaged.	Replace the bellows (6) with a new one.

For disassembly and assembly, refer to the maintenance procedure in Section 7.



## 7. Maintenance

 <b>Warning</b>	<p>Before you take off or disassemble the pressure reducing valve from the piping, be sure to close the stop valves on the inlet and outlet sides of the pressure reducing valve.</p> <p>When the assembly/disassembly is being performed, check that the pressure inside the product equals to the atmospheric pressure and allow time for the temperature to drop to a safe working temperature.</p> <p>(When the product has high temperatures and pressures, it may cause fluid ejection and serious injuries.)</p>
--	---

Disassembly, assembly, and maintenance (replacement of parts) can be performed by using general commercially available tools.

### 7-1. Check of the internal parts of the pressure-reducing valve

Clean the surface of the sliding section of the valve and the valve seat periodically (every three to six months), as they need to be always kept clean.

Parts to be checked: Valve unit

Valve (4), sealing surface of the valve seat (5), sliding section of the shaft (12), screen (15)

### 7-2. How to solve the problem of dust stuck in the valve section (simplified blow-off)

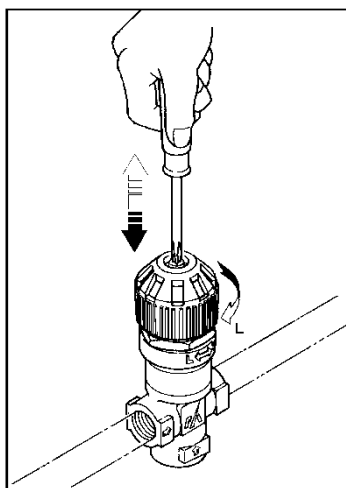

When valve leakage occurs due to dust, the type RE2 allows you to solve the problem by temporarily opening the valve widely during operation through a simple process, as shown in the figure.

Press a Phillips-head screwdriver or a similar tool against the screw (21) (handle-securing screw) and push the screwdriver down straight (by approximately 3–5 mm) against the reaction force of the spring. Repeat this several times.

If the screw can not be pushed due to a high set pressure, turn the handle in the L direction (clockwise) to reduce the secondary pressure before blowing. In this case, re-adjust the secondary pressure after blowing.

\*Be careful when blowing the pressure reducing valve, as the secondary pressure increases temporarily.

### 7-3. Disassembling space

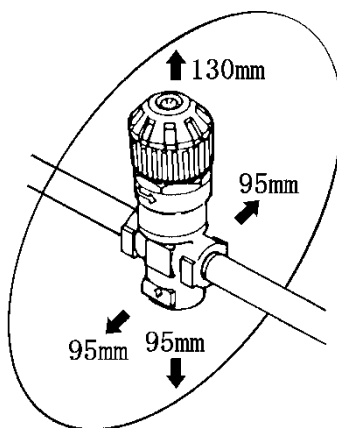

#### 7-4. How to disassemble the adjusting section

- 1) Pull the handle (10) gently and turn it to the right (direction of arrow L) to free the adjusting spring (8). (When the spring (8) is free, the handle turns very lightly.)
- 2) Take off the securing screw (21) from the head of the handle (10) by using a Phillips-head screwdriver and take off the handle (10).
- 3) Loosen the lock nut (19) using a tool, pull it up, and take off the cover (2) by using a tool (when you take of it by holding the adjusting bolt (14) at the head of the cover, the internal adjusting bolt (14) and sleeve (9) are detached together with the cover).
- 4) Take off the bellows (6).

#### 7-5. How to disassemble and assemble the valve unit

- 1) Take off the valve unit using a tool, take the shaft (12) out, and clean the sliding section.
- 2) Take off the seat bush (11) from the bottom of the valve unit using a tool, take the screen (15) out, and clean it. At this time, the return spring (13) and the valve (4) are detached together; and clean the sealing surface of the valve (4) and the valve seat (5).
- 3) After cleaning, insert the valve (4) and return spring (13) into the valve seat (5), attach the screen (15) on the outside, and tighten the seat bus (11).
- 4) Insert the shaft (12) into the sliding section of the valve seat (5) and tighten the valve unit to the body (1).

#### 7-6. How to assemble the adjusting section

- 1) After tightening the valve unit, attach the bellows (6) (including the spring stay (7)) and place the gasket (18).
- 2) Tighten the cover (2) (including the sleeve (9), adjusting bolt (14), and lock nut (19)) to the body (1) using a tool and then tighten the lock nut (19).
- 3) Attach the handle (10) to the adjusting bolt (14), place the spring (20) and washer (22), and tighten the screw (21) using a Phillips-head screwdriver.
- 4) When you assemble the cover, assemble the internal parts vertically as shown in the figure on the right.

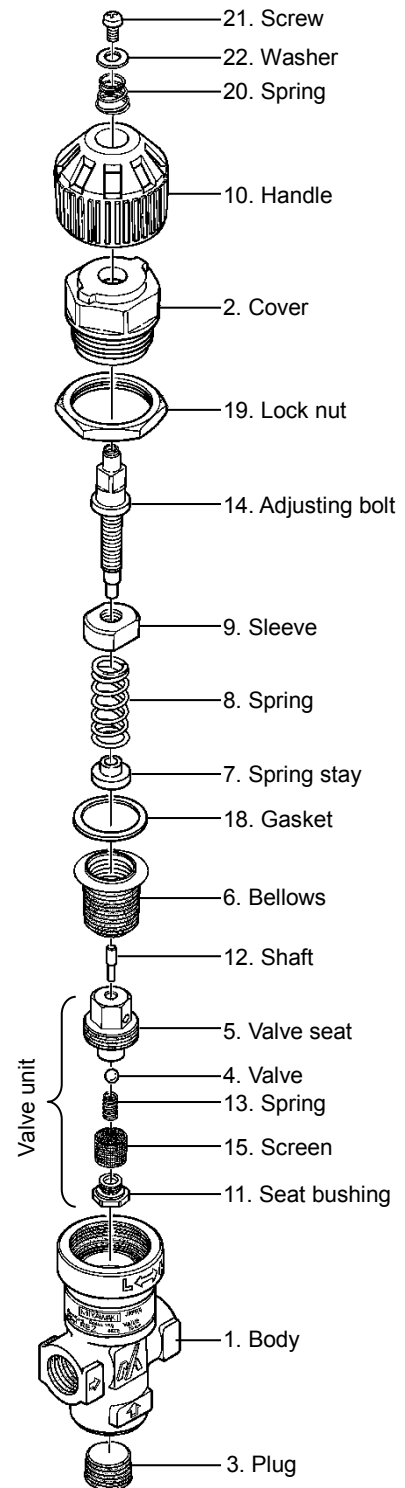

\* The tools and the torque for each part are shown in the following table.

Part No.	Parts	Across the flats	Torque	Tool
2	Cover	30 mm	40 N·m	Socket
3	Plug	8 mm	-	Hexagonal wrench key
5	Valve seat	12 mm	20 N·m	Socket
11	Seat bush	12 mm	40 N·m	Spanner
19	Lock nut	35 mm	13 N·m	Spanner
48	Screw	-	-	Phillips-head screwdriver

## 8. Warranty

### 8-1 Warranty period

The warranty period is 18 months after shipment or 12 months after installation, whichever occurs first.

### 8-2 Details of the warranty

If the product stops working correctly within the warranty period, we will repair or replace the product free of charge if the cause of the trouble is not one of the following items.

- 1) The precautions described in this manual were not observed
- 2) User's errors or mistakes such as an inappropriate installation or incorrect handling, or an excessively large impact caused by dropping
- 3) Problems caused by devices or equipment other than ours, or a disallowed use environment
- 4) When a repair or modification has been performed by anyone other than us or people who are authorized to make such repairs
- 5) Intrusion of salt or other substances that promote significant rust or corrosion or problems from fluids that contain the same substances
- 6) Consumable parts such as Gasket, O-ring, etc
- 7) Attachment or accumulation of foreign matter in the pipe, such as dust and scale
- 8) Problems from fires, natural disasters, or other force majeure which is not our responsibility

### 8-3 Warranty limitation

The remedy available under the warranty shall not exceed the sales price of the products delivered, for any cause whatsoever.

## 9 Serial number (S.No.) designation

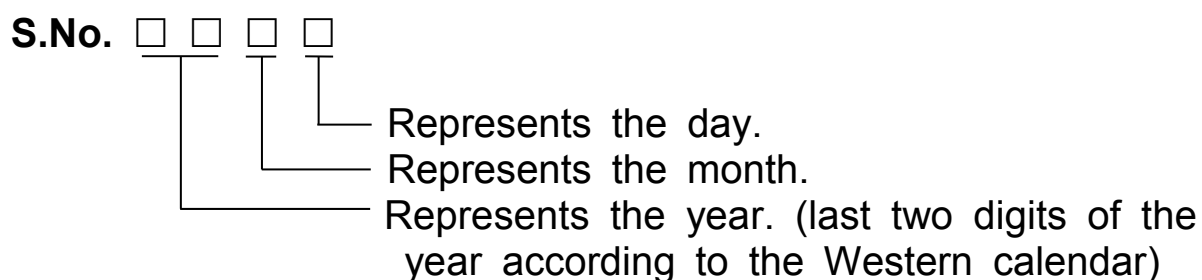

### Month designation system

Symbol	Month	Symbol	Month	Symbol	Month	Symbol	Month
1	1	4	4	7	7	X	10
2	2	5	5	8	8	Y	11
3	3	6	6	9	9	Z	12

### Day designation system

Symbol	Day	Symbol	Day	Symbol	Day	Symbol	Day
1	1	9	9	H	17	Q	25
2	2	A	10	J	18	R	26
3	3	B	11	K	19	S	27
4	4	C	12	L	20	T	28
5	5	D	13	M	21	U	29
6	6	E	14	N	22	V	30
7	7	F	15	O	23	W	31
8	8	G	16	P	24		

Example of serial number designation

1 7 1 1 → Jan 1, 2017

2 9 X M → Oct 21, 2029

## 10 Guidance for reading special product name

---



**Special symbol:**  
**Symbol apply only to special product**  
**(Please refer to table 1 for details)**  
 English letter after “-“

**Model symbol:**  
**Product model number**

Table 1 Symbol description

Suffix	Special contents
A	Trap for high-pressure gas installed property (only for Gas Trap)
C	Blow valve attached
K	Change of gasket
L	Special face to face dimension
M	Change of parts material
P, T	Change of operating pressure, temperature, condensate capacity, etc
R	Change of screen mesh
V	Change of air vent
X	Other than mentioned above or complex of special contents above

- 
- For any questions about the product that you purchased or about the details in this user's manual, please contact the following.
  - © 2017 MIYAWAKI INC.  
This user's manual may not be reproduced or copied in whole or in part, without the written consent of MIYAWAKI INC.
  - Some special specifications of the product you have, may found to be different from the ones in the user's manual. If you have any question, please contact MIYAWAKI, our local authorized agent, or the place where you purchased.
-



**INTERNATIONAL SALES DEPT.**

2-1-30, Tagawakita, Yodogawa-ku, Osaka, 532-0021, Japan

Tel: +81-6-6302-5549

www.miyawaki.net e-mail: export@miyawaki-inc.co.jp

EU Importer and Authorized representative:



**MIYAWAKI GmbH**

Birnbaumsmühle 65, 15234 Frankfurt (Oder), Germany

Tel: +49-335-4007-0097

www.miyawaki.net e-mail: info@miyawaki.de

China Importer and Authorized representative:



**MIYAWAKI WEST Co.,ltd**

Room 1705, No.1, Building, No.311, Yanxin Road, Huishan Economic Development Zone,  
Wuxi, Jiangsu, China

Tel: +86-510-8359-5125

www.miyawaki-inc.com.cn e-mail: mywkwest@miyawaki-inc.com.cn

808045-03 2007

**RE2**