

**INSTALLATION, OPERATION and
MAINTENANCE MANUAL**

**Pilot Operated
Pressure Reducing Valve**

RE3



SAFETY

The following warnings and cautions are shown at appropriate places in this manual.



Failure to observe this type of precaution may lead to serious injury or death.



Failure to follow this type of precaution can lead to injury or damage to equipment and property.

S No. on the name plate of our product indicates a manufacturing date.

The following 4-digit or 9-digit 'S.No.' is displayed on the product.

●For 4-digit display

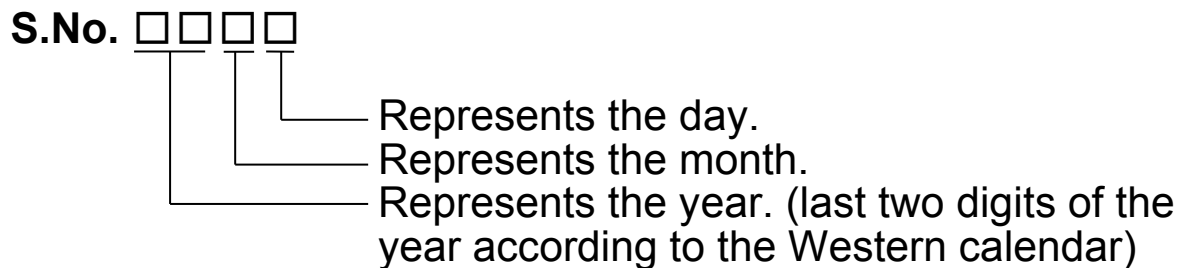

Example of serial number designation
1 7 1 1 → Jan 1, 2017
29XM → Oct 21, 2029

●For 9-digit display

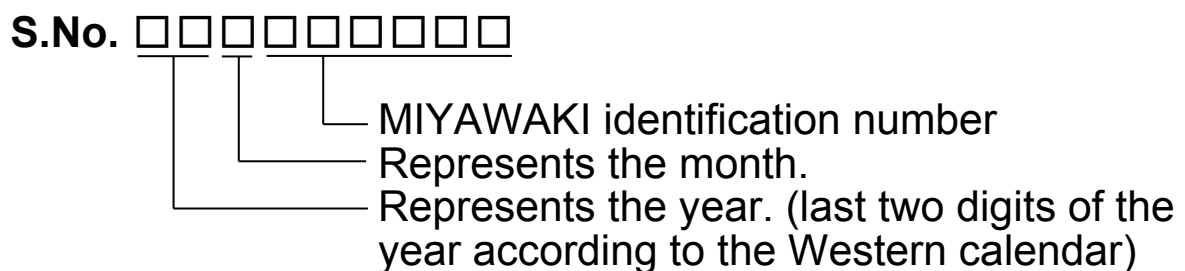

Example of serial number designation
1 7 1 1 2 C 0 2 0 → Jan , 2017
2 9 X 0 5 M 0 5 0 → Oct , 2029

Month designation system

Month	1	2	3	4	5	6	7	8	9	10	11	12
Symbol	1	2	3	4	5	6	7	8	9	X	Y	Z

Day designation system

Day	1	2	3	4	5	6	7	8	9	10	11	12
Symbol	1	2	3	4	5	6	7	8	9	A	B	C

Day	13	14	15	16	17	18	19	20	21	22	23	24
Symbol	D	E	F	G	H	J	K	L	M	N	O	P

Day	25	26	27	28	29	30	31
Symbol	Q	R	S	T	U	V	W

CONTENTS

1. INTRODUCTION	P.1
2. TECHNICAL DATA AND DIMENSION.....	P.1
3. INSTALLATION	P.2
4. INSTALLATION EXAMPLE	P.3
5. ADJUSTMENT.....	P.4
6. TROUBLE SHOOTING.....	P.4
7. MAINTENANCE	P.6
8. WARRANTY	P.10
★ GUIDANCE FOR READING SPECIAL PRODUCT NAME	P.11

1. Introduction

The MIYAWAKI – pressure reducing valve RE 3 is a pilot operated pressure regulator equipped with micro bellows and designed for use in steam lines.

Prior to using the RE3 , read this manual thoroughly to understand the correct handling and operating procedure.

The manual should be used by experienced personnel as a guide to the installation and maintenance of the RE 3.

We ask you to contact MIYAWAKI or its local representative if further information is required.

2. Technical Data and Dimension

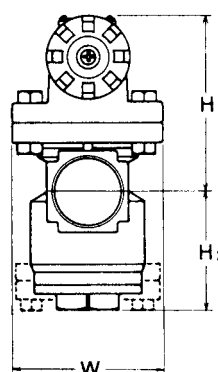
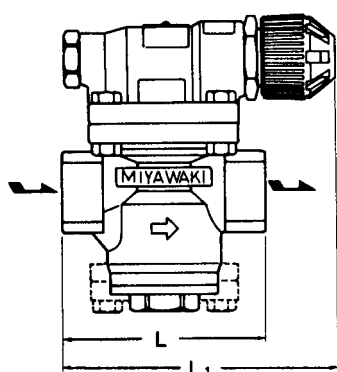

Pressure Reducing Valve Type RE 3

Connection: Screwed

Size (inch): $\frac{1}{2}$ $\frac{3}{4}$ 1, 1 $\frac{1}{4}$ 1 $\frac{1}{2}$ 2

Maximum Primary (Inlet)Pressure: 16 bar / 230 psig

Adjustable Secondary (Outlet)
Pressure: 0,35 to 12 bar / 4,4 to 174 psig

Maximum Operating Temperature: 220°C / 428°F

Maximum Pressure
Reducing Ratio: 20 : 1

Minimum Differential
Pressure: 0,7 bar / 10 psi

Type	Size	Connection	Dimensions (mm)					Dimensions (inch)					Weight	
			L	L ₁	H ₁	H ₂	W	L	L ₁	H ₁	H ₂	W	kg	lb
RE3	$\frac{1}{2}$	Screwed	90	127	87	58	74	3.5	5.0	3.4	2.3	2.9	2,7	5.9
	$\frac{3}{4}$		95	130	87	58	74	3.7	5.1	3.4	2.3	2.9	2,8	6.2
	1"		100	132	87	58	74	3.9	5.2	3.4	2.3	2.9	2,8	6.2
	1 $\frac{1}{4}$ "		130	155	111	73	96	5.1	6.1	4.4	2.9	3.8	6,2	13.6
	1 $\frac{1}{2}$ "		130	155	111	73	96	5.1	6.1	4.4	2.9	3.8	6,3	13.9
	2"		140	157	121	79	110	5.5	6.2	4.8	3.1	4.3	8,3	18.3

3. Installation

- 3.1. The pressure reducing valve should be installed in a horizontal pipe with the operating part including the adjust unit turned upwards, with suitable bypass and isolating valves.
- 3.2. To prevent water hammer and vibrations caused by incoming condensate it is necessary to install a steam trap before the pressure reducing valve.
- 3.3. If you expect the average flow velocity to rise above 30m/sec, it is recommended to increase the size of the pipe.
- 3.4. Pressure reducing valves may not be installed parallel. These valves are to be used individually and independently.
- 3.5. In case the pressure reducing ratio exceeds 20 : 1 (for instance the secondary pressure is lower than 0,8 bar at 16 bar primary pressure), the pressure reduction is to be made in two steps. In that case, a distance of at least 3 meters has to be kept between the two pressure reducing valves.
- 3.6. The distance between the pressure reducing valve and a solenoid valve must be of at least 3 meters, if a solenoid valve with on/off function is installed upstream or downstream of the pressure reducing valve. Otherwise, the pressure reducing valve may not function in a stable way while the valve is opening or closing.
- 3.7. If a control valve is installed downstream of the pressure reducing valve, the distance between the pressure reducing valve and the control valve must be of at least 2 meters. The disregard of this recommendation may cause an unstable function of the pressure reducing valve as well.
- 3.8. As a pressure reducing valve used for steam normally does not close completely, it is recommended to install a steam trap downstream for the case that the steam flow comes to zero and condensate is arising in the steam line behind the pressure reducing valve (dead end service).
- 3.9. To prevent an unusual rise of the outlet pressure a safety valve has to be installed.
- 3.10. The pipe in which the pressure reducing valve is installed, must be fixed so that the weight and the vibration of the pipe do not directly influence the pressure reducing valve.
- 3.11. Blow down the piping that leads to the PRV's inlet from any dirt and scale before the first start-up of the pressure reducing valve. This is particularly important in case of the start-up of the pressure reducing valve after a long time of shut-down.
- 3.12. Before a long shut-down of the pressure reducing valve the condensate must be completely discharged from the pipe. Furthermore the stop valves before and behind the pressure reducing valve have to be closed.

- 3.13. The distance between the pressure reducing valve and a downstream pressure gauge should be of at least 1 meter.
- 3.14. The length of the straight section of the upstream piping and the length of the straight section of the downstream piping should be each at least 10 pipe diameters.
- 3.15. The steam trap and the pressure reducing valve should both be protected with a strainer. The strainer should be installed in such a way that the screen will point sideways to avoid the accumulation of condensate in the area of the screen.

4. Installation example

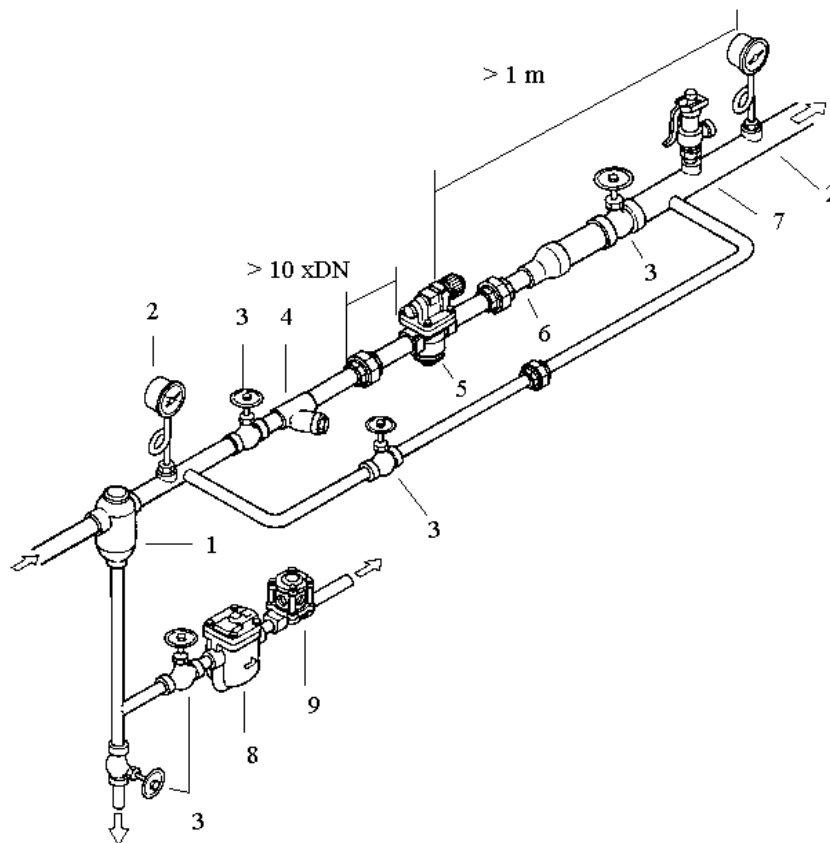

- 1. Separator
- 2. Pressure Gauge
- 3. Stop Valve
- 4. Strainer
- 5. Pressure Reducing Valve RE 3
- 6. Reducer
- 7. Safety Valve
- 8. Steam Trap Type ES
- 9. Sight Glass Type TS 1

5. Adjustment

- 5.1. After the installation and before the adjustment of the pressure reducing valve close the stop valves before and behind the pressure reducing valve and open the bypass to remove all condensate and dirt from the pipe.
- 5.2. Close the bypass valve and pull the green handle while the stop valves are closed. Turn the handle clockwise (looking from the outlet side towards the inlet side) to release the adjust spring. The handle will turn easily when the spring gets free.
- 5.3. Open the stop valve downstream slightly. Than open the stop valve upstream slowly.
- 5.4. Pull out the handle again and turn it towards "H" (counterclockwise, looking from the outlet side towards the inlet side) until the required pressure is attained.
- 5.5. Release the handle so that it will engage.
- 5.6. Now, open the stop valve downstream completely and check again the setted pressure.
- 5.7. In case of a shut-down of the equipment the stop valve downstream must be closed at first. The stop valve upstream is to be closed as a second step. When the equipment will start up again open the stop valve downstream at first and than open the stop valve upstream slowly.

Remarks:

1. Please, wear gloves while installing the valve.
2. Do not touch the lock nut except when disassembling the valve.

6. Trouble Shooting

Problem	Cause	Solution
The downstream pressure doesn't meet the set value.	Pressure was set incorrectly.	Turn the handle (22) to correct.
	The upstream stop valve is closed .	Open the valve.
	The downstream stop valve is closed .	Open the valve.
	The pressure gauge does not work properly.	Replace the pressure gauge.
	The steam quantity upstream is too small.	Check the steam quantity by using a bypass valve.
	Insufficient capacity of the pressure reducing valve.	Check the steam quantity by using a bypass valve and choose the correct pressure reducing valve.

	The screen (20) of the pressure reducing valve is plugged.	Remove the plug (3) and clean the screen.
	The screen (21) before the pilot valve is plugged.	Remove the plug (10) and clean the screen (21).
	Irregular movement of the pilot valve (11) due to dirt.	Remove the plug (10) and clean the pilot valve.
	Irregular movement of the main valve (4) due to dirt.	Remove the plug No.3 (for 1/2-1") or take off the bottom flange (3) (for 1 1/4-2") and clean the main valve (4).
	Irregular movement of the piston (7) and the cylinder (8).	Clean or replace the piston (7) and the cylinder (8).
	The openings connecting the body with the cover are plugged.	Remove the cover (2) and clean the openings.
The secondary pressure exceeds the set pressure.	Pressure was not set correctly.	Turn the handle (22) to correct.
	Inlet and outlet were installed the wrong way round.	Install correctly according to the flow direction.
	The downstream stop valve is closed.	Open the stop valve.
	The valve in the bypass pipe is open or is leaking.	Close or replace the valve.
	The pressure gauge isn't working properly.	Replace the pressure gauge.
	Irregular movement of the pilot valve (11) due to dirt.	Remove the plug (10) and clean the pilot valve (11).
	Irregular movement of the main valve (4) due to dirt.	Remove the plug (3) (1/2-1") or take off the bottom flange (1 1/4 - 2") and clean the main valve (4).
	Irregular movement of the piston (7) due to dirt.	Remove the cover (2) and clean the piston (7).
	The pilot valve (11) is leaking because of dirt.	Remove the plug (10) and clean the pilot valve (11) and the valve seat (12).
	The main valve (4) is leaking because of dirt.	Remove the plug (3) (1/2-1") or take off the bottom flange (1 1/4 - 2") and clean the main valve (4) and the Seat (5).
	The bellows (14) are damaged or do not seal completely.	Remove the adjust cover (9) and change the bellows (14).
	Little or no steam demand.	Install a steam trap and a safety valve downstream.

7. Maintenance

The disassembly, the assembly and the replacement of parts may, in general, be done with tools customary in the market.

When you disassemble the valve, pay attention that you start the maintenance work only when the internal parts have cooled down and are not under pressure.

7.1. Piston and Cylinder Liner

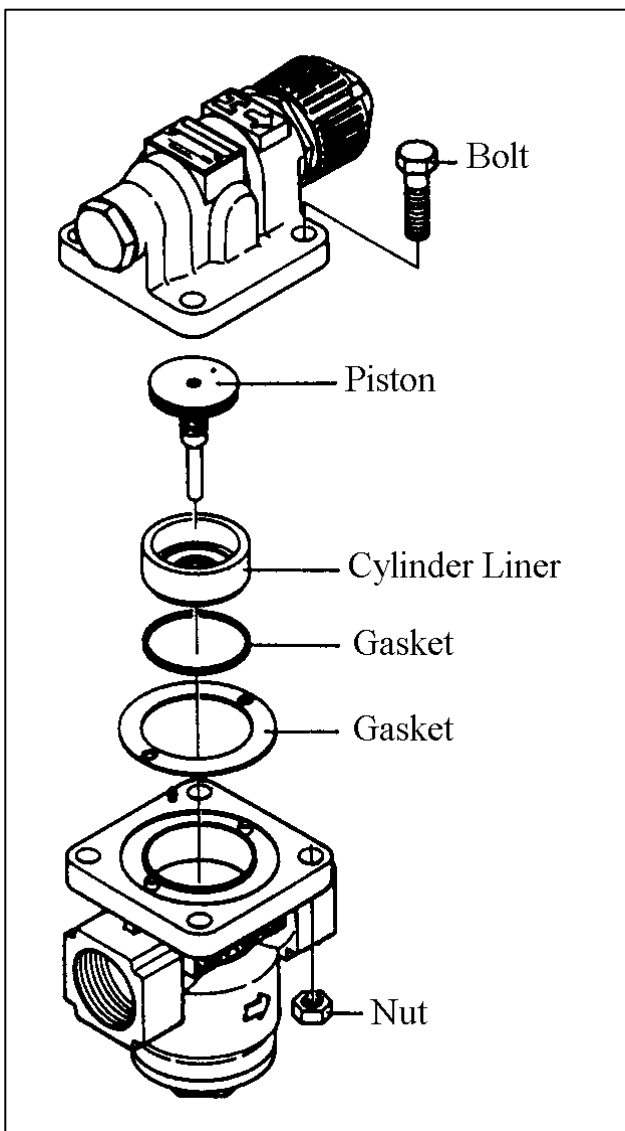

Nr.. 37 - Bolt, Nut

Size	1/2 - 1"	1 1/4 - 2"
Bolt Size	12 mm	17 mm
Torque	200kgf • cm	300kgf • cm

Spare Parts

No.	Parts Name
7	Piston
8	Cylinder Liner
19	Piston Ring
30	Gasket
26	Gasket

7.2. Valve and Valve Seat

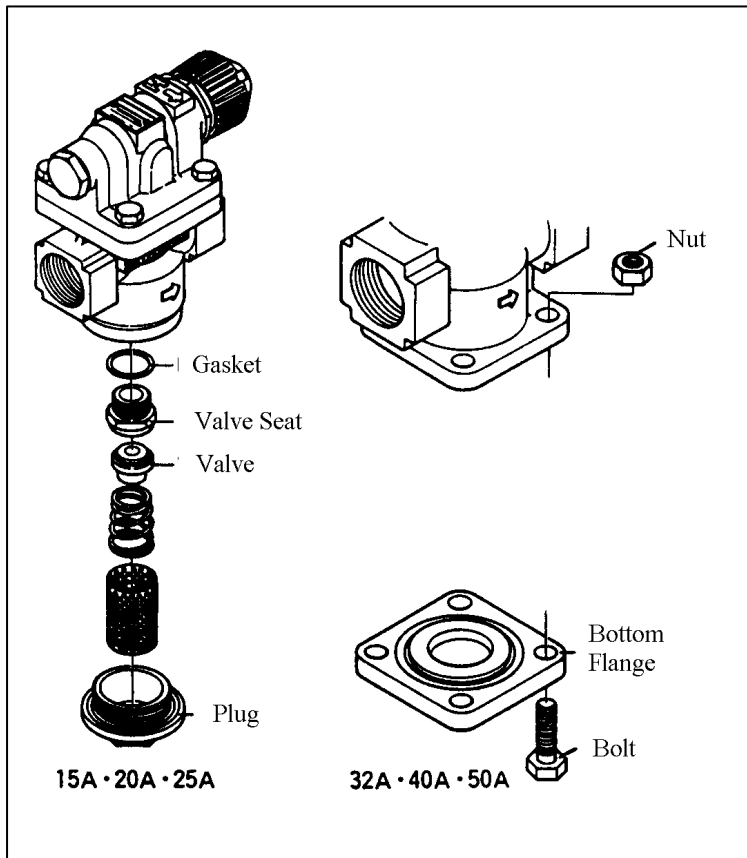

Nr. 3 - Plug

Size	1/2 - 1"
Plug size	30 mm
Torque	800 kgf • cm

Nr. 38 - Bolt

Size	1 1/4 - 2"
Bolt Size	17 mm
Torque	300 kgf • cm

Spare Parts

No.	Parts Name
25	Gasket
5	Valve Seat
4	Valve

Nr. 5 - Valve Seat

Size	1/2 - 1"	1 1/4 - 1 1/2"	2"
	24 mm	36 mm	41 mm
Torque	600kgf • cm	1200 kgf • cm	1500 kgf • cm

7.3. Strainer Pilot Valve

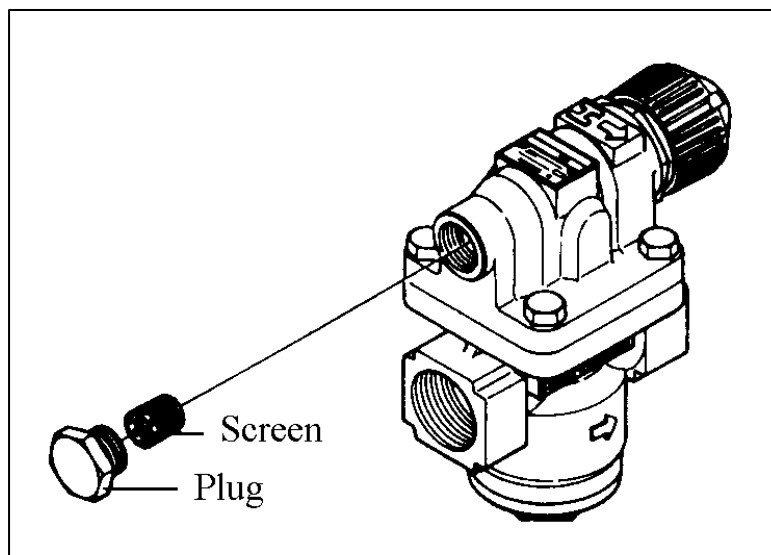

Nr. 10 - Plug

Plug Size	24 mm
Torque	200 kgf • cm

7.4. Valve Seat and Bellows

Spare Parts

No.	Parts Name
28	Gasket
14	Micro Bellows
12	Valve Seat Unit

Nr. 9 – Adjust Cover

Measurement	30 mm
Torque	900 kgf • cm

Nr. 12 – Valve Seat

Measurement	14 mm
Torque	300 kgf • cm

Nr. 34 – Lock Nut

Measurement	35 mm
Torque	-

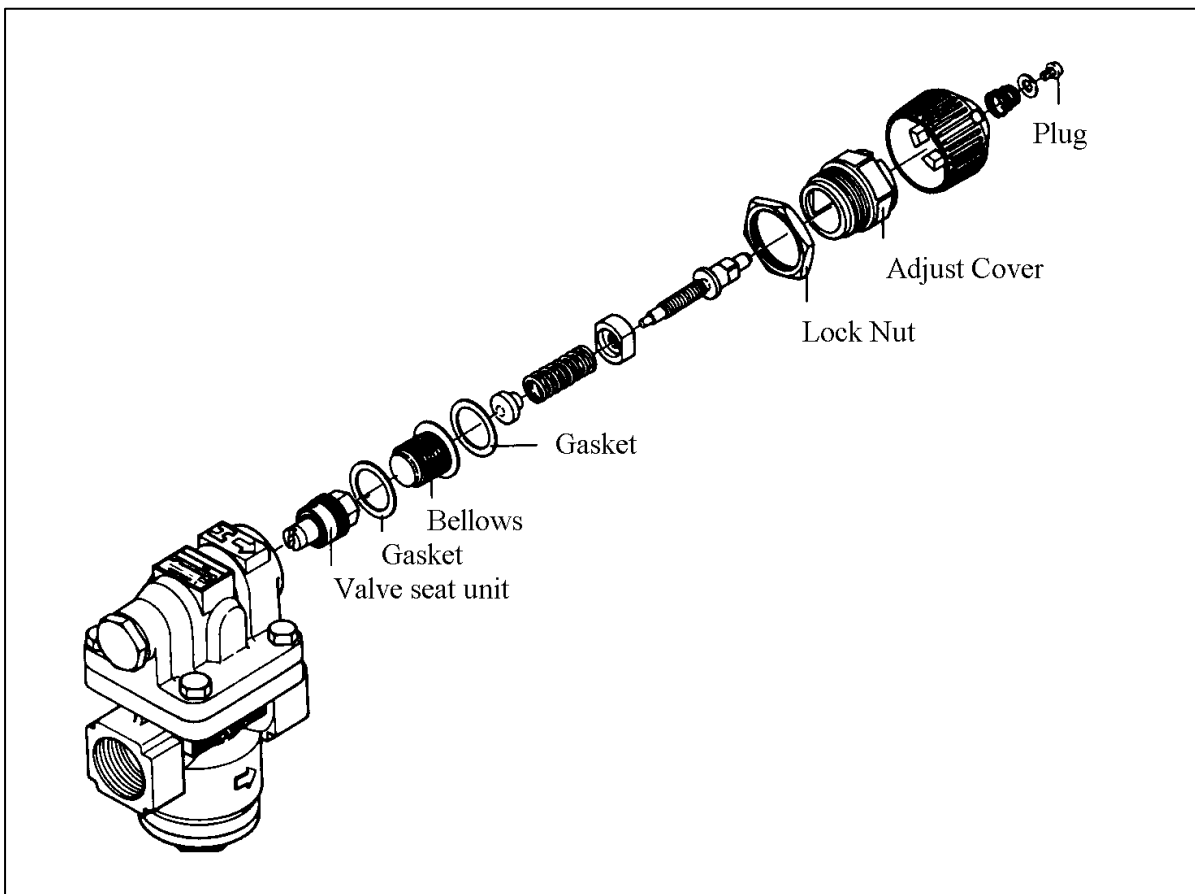

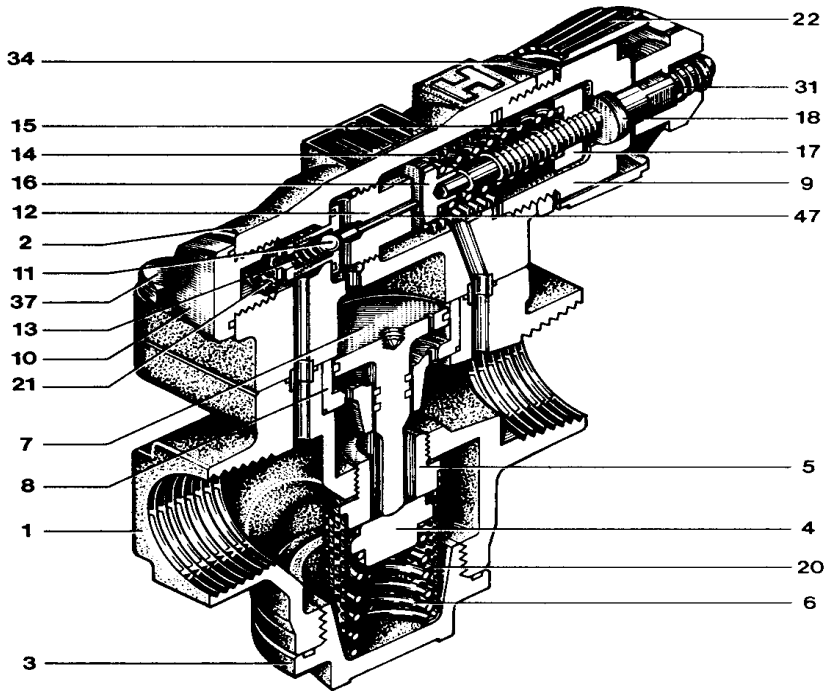

Material

Parts-No.	Parts Name	Material
1	Body	Brass
2	Cover	Brass
3	Plug(1/2-1") Bottom Flange (1 1/4-2")	Brass Brass
4	Valve	Stainless Steel
5	Disc	Stainless Steel
6	Spring	Stainless Steel
7	Piston	Brass
8	Cylinder Liner	Brass
9	Adjust Cover	Brass
10	Plug	Brass
11	Pilot Valve	Stainless Steel
12	Valve Seat	Stainless Steel
13	Spring	Stainless Steel
14	Bellows	Stainless Steel
15	Spring	Special Alloy
16	Spring Holder	Stainless Steel
17	Sleeve	Brass
18	Adjust Bolt	Stainless Steel
20	Screen	Brass
21	Screen	Stainless Steel
22	Handle Unit	Plastic
31	Spring	Stainless Steel
34	Lock Nut	Brass
37	Bolt	Carbon Steel
47	Shaft	Stainless Steel

8. WARRANTY

8.1 Warranty period

The warranty period is 18 months after shipment or 12 months after installation, whichever occurs first.

8.2 Details of the warranty

If the product stops working correctly within the warranty period, we will repair or replace the product free of charge if the cause of the trouble is not one of the following items.

- 1) The precautions described in this manual were not observed
- 2) User's errors or mistakes such as an inappropriate installation or incorrect handling, or an excessively large impact caused by dropping
- 3) Problems caused by devices or equipment other than ours, or a disallowed use environment
- 4) When a repair or modification has been performed by anyone other than us or people who are authorized to make such repairs
- 5) Intrusion of salt or other substances that promote significant rust or corrosion or problems from fluids that contain the same substances
- 6) Consumable parts such as Packing, Gasket, O-ring, Diaphragm, etc
- 7) Attachment or accumulation of foreign matter in the pipe, such as dust and scale
- 8) Problems from fires, natural disasters, or other force majeure which is not our responsibility

8.3 Warranty limitation

The remedy available under the warranty shall not exceed the sales price of the products delivered, for any cause whatsoever.

★GUIDANCE FOR READING SPECIAL PRODUCT NAME

○○○-○○-□

Special symbol:
 symbol apply only to special product
 (Please refer to table 1 for details)
 English letter after “-“
 Model symbol:
 Product model number

Table 1 Symbol description

Suffix	Special contents
A	Trap for high-pressure gas installed property
C	Blow valve attached
K	Change of gasket
L	Special face to face dimension
M	Change of parts material
P, T	Change of operating pressure, temperature, condensate capacity, etc
R	Change of screen mesh
V	Change of air vent
X	Other than mentioned above or complex of special contents above

For any questions about the product that you purchased or about the details in this user's manual, please contact the following.

- © 2023 MIYAWAKI INC.

This user's manual may not be reproduced or copied in whole or in part, without the written consent of MIYAWAKI INC.

- Some special specifications of the product you have, may found to be different from the ones in the user's manual. If you have any question, please contact MIYAWAKI, our local authorized agent, or the place where you purchased.
-



If you need any assistance regarding this manual, please contact MIYAWAKI INC.'s International Sales Dept. or its local representative. By scanning QR Code, you can access inquiry form.



INTERNATIONAL SALES DEPT.

2-1-30, Tagawakita, Yodogawa-ku, Osaka, 532-0021, Japan

Tel: +81-6-6302-5549

www.miyawaki-inc.com/en e-mail: export@miyawaki-inc.co.jp

EU Importer and Authorized representative:



Birnbaumsmühle 65, 15234 Frankfurt (Oder), Germany

Tel: +49-335-4007-0097

www.miyawaki.de e-mail: info@miyawaki.de

China Importer and Authorized representative:



Room902 ,Building 8, Huaqing Chuangzhi Park, No.3 Qingyan Road, Huishan District, Wuxi City Jiangsu Province China

Tel: +86-510-8359-5125

www.miyawaki-inc.com.cn e-mail: mywkwest@miyawaki-inc.com.cn

818046-06 2307

RE3