

**LEVER FREE
BALL FLOAT STEAM TRAP**

G20N/G21N-F/GC20

USER'S MANUAL



**G20N-F
Flanged**



**G20N
Screwed**



**G21N-F
Flanged**

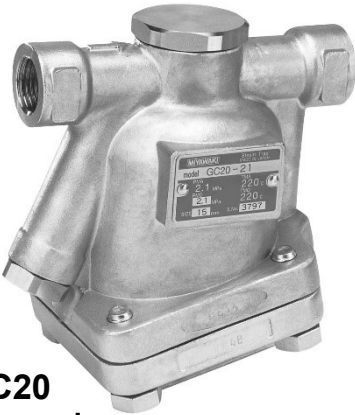

**GC20
Screwed**



**GC20-F
Flanged**



SAFETY GUIDE

The model G20N/G21N-F/GC20 is a ball float steam trap that has superior durability and is equipped with a membrane capsule type air vent.

In order to get maximum benefit from this product, be sure to read this manual before installing it.

The following warnings and cautions are shown at appropriate places in this manual.



Failure to observe this type of precaution may lead to serious injury or death.



Failure to follow this type of precaution can lead to injury or damage to equipment and property.

Table of Contents

1	SPECIFICATIONS AND MARKINGS	1
2	CONSTRUCTION DETAILS	2
3	INSTALLATION	3
4	MAINTENANCE	5
5	TROUBLESHOOTING	13
6	WARRANTY	14
7	SERIAL NUMBERS (S.No.) DESIGNATION	15
8	GUIDANCE FOR READING SERIAL PRODUCT NAME	16

1 SPECIFICATIONS AND MARKINGS



WARNING

Be sure not to use this product at higher pressures than the specified maximum operating pressure (PMO) or at temperatures higher than the specified maximum operating temperature (TMO).

The following items are displayed on the name plate or the side of the product.

Check each item to avoid misuse of the product.

(1) Maximum allowable pressure (PMA): 2.1 MPa (21 bar/305 psig)

(2) Maximum allowable temperature (TMA): 220°C (428°F)

(3) Maximum operating pressure (PMO):

G20N-3(F)/G21N-3F/GC20-3(F): 0.3 MPa (3 bar/43 psig)

G20N-8(F)/G21N-8F/GC20-8(F): 0.8 MPa (8 bar/116 psig)

G20N-21(F)/G21N-21F/GC20-21(F): 2.1 MPa (21 bar/305 psig)

(4) Maximum operating temperature (TMO): 220°C (428°F)

(5) Size:

15mm (1/2"), 20mm (3/4), 25mm (1")

(6) Year of production: The two leftmost digits in the four-digit or nine-digit 'S. No.' are the last two digits of the year of production.

(7) Flow direction: Shown by an arrow.

(8) Body material:

G20N/G21N-F: FCD450

GC20: SCS13A

(9) Model symbol: Showing the product name

For more details regarding dimensions and other specifications, refer to the catalog.

2 CONSTRUCTION DETAILS

G20N/G21N-F model

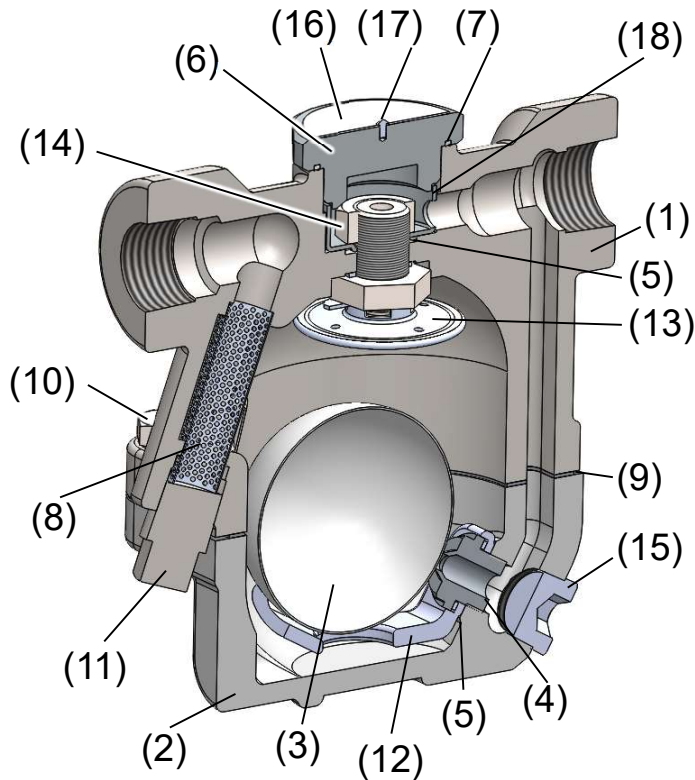

- (1) Body
- (2) Bottom cover
- (3) Float
- (4) Valve seat
- (5) Seat gasket
- (6) Air vent plug
- (7) Air vent plug gasket
- (8) Screen (20 mesh or equivalent)
- (9) Cover gasket
- (10) Cover bolt
- (11) Screen plug
- (12) Valve holder
- (13) Air vent
- (14) Nut
- (15) Plug
- (16) Name plate
- (17) Rivet
- (18) Protector

GC20 model

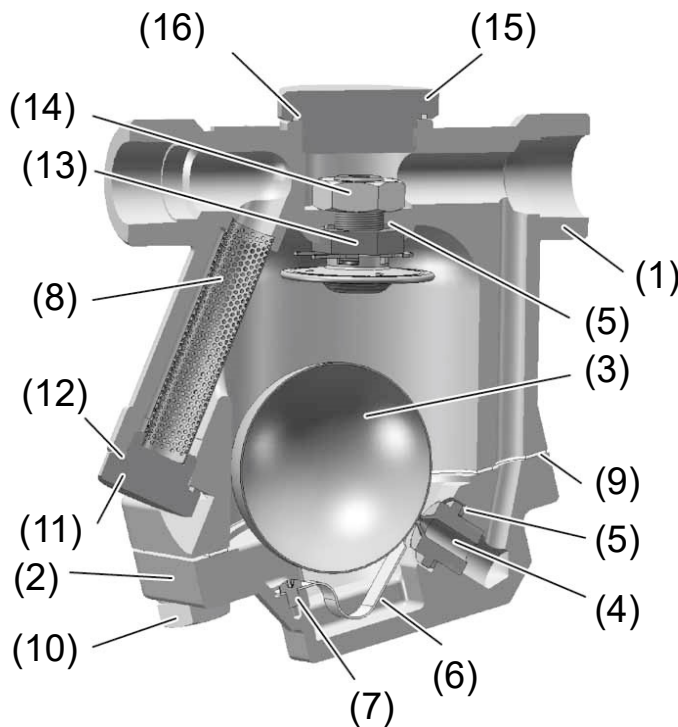

- (1) Body
- (2) Bottom cover
- (3) Float
- (4) Valve seat
- (5) Seat gasket
- (6) Bimetal
- (7) Screw (Phillips)
- (8) Screen (20 mesh or equivalent)
- (9) Cover gasket
- (10) Cover bolt
- (11) Screen plug
- (12) Screen plug gasket
- (13) Air vent
- (14) Nut
- (15) Air vent plug
- (16) Air vent plug gasket

3 INSTALLATION



WARNING

Pay very careful attention when working in hazardous environments. There is a risk of explosion and the possibility of dangerous gases leaking. Always check whether the pipeline contains flammable, high pressure or high temperature materials before starting to work

- **Make sure that isolation valves are installed on both the upstream and downstream lines.**



CAUTION

- **Before installing the product, open both isolation valves to blow out any debris or dirt inside the pipeline.**
 - **After blowing out the line, before starting to work, close the isolation valves and allow time for the temperature to drop to a safe working temperature.**
 - **When installing the product, be sure to leave clearance for maintain it.**
- (1) Remove the dustproof seals covering both connections.
 - (2) Check the flow direction indicated on the side of the body.
 - (3) When installing G20N/G21N-F/GC20 in a horizontal line, the air vent plug on the main body of the trap must be facing up. Also, be sure to maintain a slight slope (1/200 mm) to the line, so that any condensate will flow smoothly.
 - (4) Open the isolation valve on the upstream line and make sure the product works normally.

G20N/G21N-F model

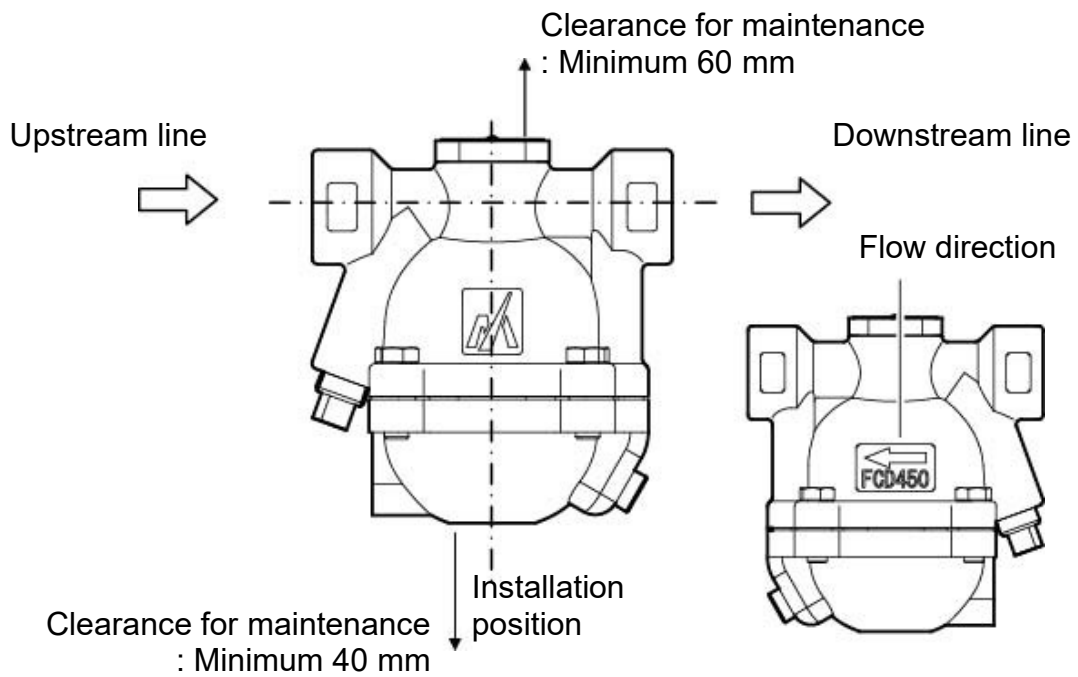

GC20 model

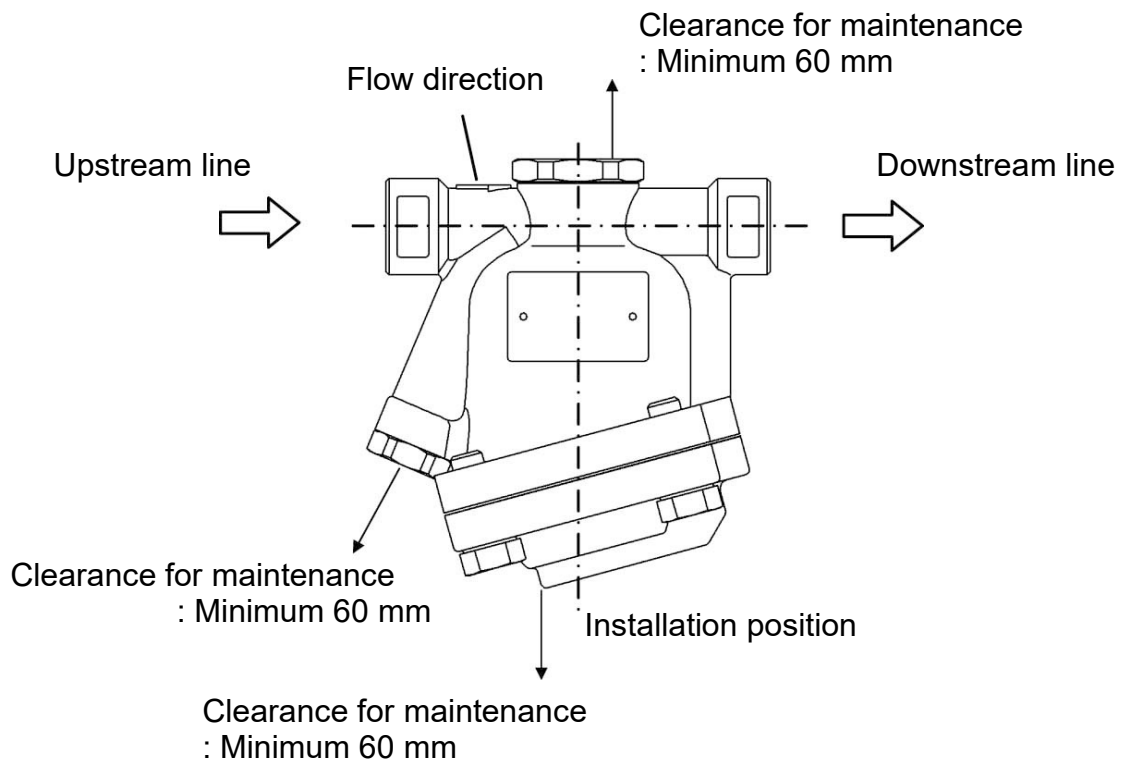

4 MAINTENANCE



CAUTION

- **When replacing parts, make sure the replacement parts are supplied by Miyawaki.**

The performance of steam traps deteriorates gradually over time due to wear, corrosion or dirt accumulating around the valve and the valve seat. Please conduct periodic diagnosis of traps in order to keep steam control systems and equipment working well.

4.1 Tools for Diagnosis Steam Traps

■ Dr. Trap

It is a diagnostic tool with hardware (diagnostic equipment) that performs automatic diagnosis at high speed (maximum 10 seconds) and exclusive aggregate analysis software from the vibration and temperature information of the trap.

Diagnostic information is recorded in the diagnostic equipment and data can be transferred to the software. As a result, high-speed aggregate analysis, quantitative grasp of steam leakage and loss amount are possible.

■ Dr. Trap Jr.

It is an inexpensive and simple diagnostic tool using hardware (steam trap checker) with vibration sensor, temperature sensor and exclusive aggregate analysis software. From the vibration and temperature information of the trap, the judgment such as good or fail is made by a diagnostician. By inputting the vibration value detected by the steam trap checker to the aggregate analysis software, it is possible to quantitatively grasp the amount of steam leakage and money loss.

Caution:

Even if both diagnostic tools are used, accurate diagnosis results may not be obtained depending on the location and installation status of the steam trap, or the type and operating condition of the steam trap.

For details, please contact MIYAWAKI, our local authorized agent, or the place where you purchased.

G20N/G21N-F model

Disassembling the trap

- 1) Loosen the 4 cover bolts (10) and then the bottom cover (2) can be lowered to remove it.
- 2) Remove the float (3), the valve seats (4), the seat gasket (5), and the valve holder (12), in that order.

Disassembling the air vent

- 1) Loosen the 4 cover bolts (10) and then the bottom cover (2) can be lowered to remove it.
- 2) Remove the air vent plug (6).
- 3) While holding the air vent (13) with your hand and loosen the nut (14). Then lower the air vent to remove it.
- 4) In case of replacing the protector (18), remove it by pulling upwards.

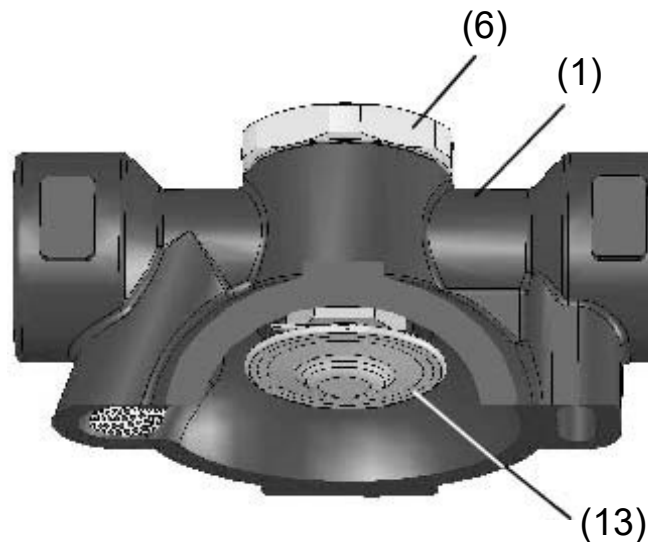

Disassembling the screen

- 1) Remove the screen plug (11).
- 2) Remove the screen (8) from the screen plug (11).

Repair the trap according to the instructions in Section 5 "Troubleshooting".

After repairing the trap, reassemble the parts, reversing the order in which they were removed.

Reassembling the screen

- 1) Have thread sealing tape around the threads on the screen plug (11).
- 2) Put the screen (8) back on the screen plug (11).
- 3) Screw the screen plug (11) into the body (1), and then fasten the screen plug (11).
 - * Make sure that the head of the screen is mated with the body.
 - * From the screen plug (11) head to body (1) should be $14.0 \sim 14.6$ mm, to prevent compression fracture of the screen (8).

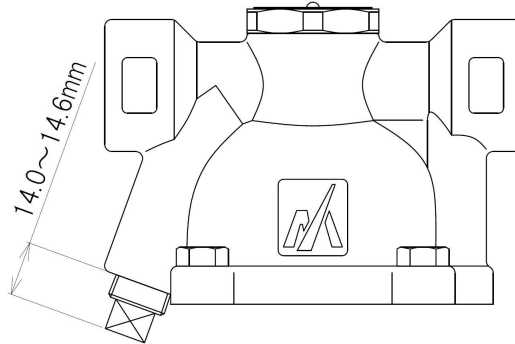

Reassembling the air vent

- 1) Install the seat gasket (5) on the air vent (13).
 - * To prevent seizure, apply a small amount of anti-seize lubricant to both sides of the seat gasket (5) and to the threads of the air vent (13).
- 2) Put the guide of the protector (18) into the guide groove on the body (1).
 - * At this time, match the outlet hole of the protector (18) to the outlet hole of the body (1).
- 3) Put the air vent (13) back into its correct position from the bottom of the body (1).
- 4) Fasten the air vent (13), from the air vent plug section on the upper side of the body (1), using the nut (14).
 - * Now, put the hexagonal air vent into the groove on the body to prevent the air vent from spinning free.
- 5) Fasten the air vent plug (6) onto the body (1).

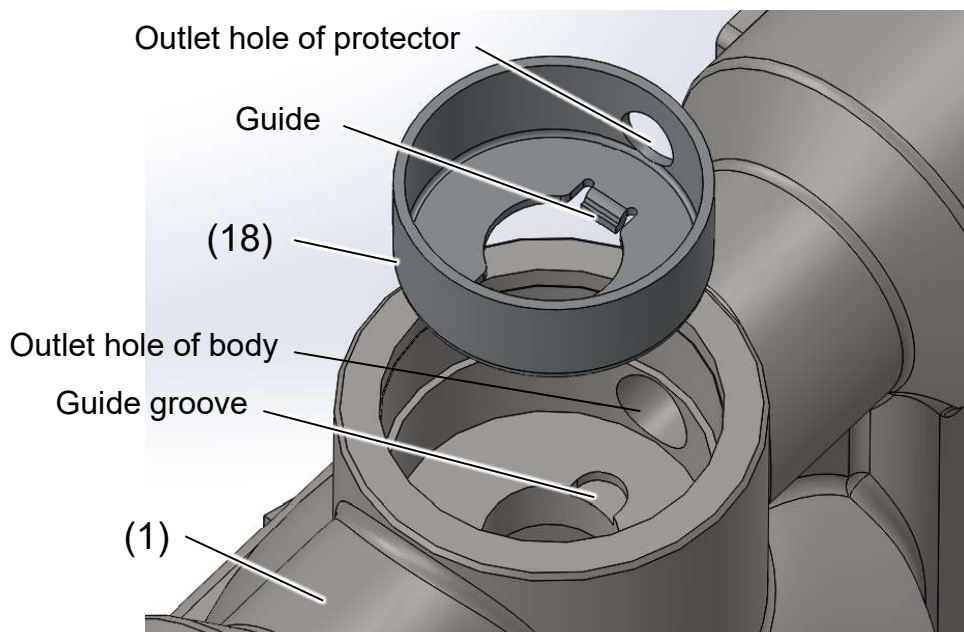

Reassembling the body

1) Reinstall the seat gasket (5) on the valve holder (12).

* To prevent seizure, apply a small amount of anti-seize lubricant to both sides of the seat gasket (5) and to the sealing surface (on the bottom cover mounting side) of the valve holder (12).

2) Reinstall the valve holder (12) on the bottom cover (2).

3) Place the threaded part of the valve seat (4) into the valve holder hole (12), and screw it into the bottom cover (2).

* To prevent seizure, apply a small amount of anti-seize lubricant to the threads of the valve seat (4).

4) Place the cover gasket (9) and the float (3) on the bottom cover (2) and then reinstall the bottom cover on the body (1).

When installing the bottom cover, make sure to reinstall the body (1) and the bottom cover (2) in the same direction. Don't reverse the left and right sides. Fasten the body (1) with the cover bolts (10) which are inserted from the body side.

* To prevent seizure, apply a small amount of anti-seize lubricant to the threads of the cover bolts (10).

* When tightening the cover bolts, tighten them evenly to prevent them from placing uneven pressure on the cover.

* The torque for each part is shown in the following table.

Parts	Tools	Across the flats	Torque
Valve seat (4)	Torque wrench	13 mm (0.51")	25N·m
Cover bolt (10)	Torque wrench	13 mm (0.51")	28N·m
Nut (14)	Torque wrench	17 mm (0.67")	25N·m
Air vent plug (6)	Torque wrench	38 mm (1.50")	50N·m

* The cover gasket (9) should be replaced with a new one every time you disassemble the trap. When you remove the cover gasket (9) attached to the sealing surface, please pay attention that you do not damage the sealing surface.

* The protector (18), the seat gasket (5), or the air vent plug gasket (7) can be used repeatedly, but if the surface of the seat gasket (5) or air vent plug gasket (7) is damaged or distorted, please replace it with a new one.

GC20 model

Disassembling the trap

- 1) Loosen the 4 cover bolts (10) and then the bottom cover (2) can be lowered to remove it.
- 2) Remove the float (3), valve seat (4), seat gasket (5), and bimetal (6). The bimetal (6) is secured to the cover (2) with a screw (Phillips head screw) (7).

Disassembling the air vent

- 1) Loosen the 4 cover bolts (10) and then the bottom cover (2) can be lowered to remove it.
- 2) Remove the air vent plug (15).
- 3) While holding the air vent (13) with your hand and loosen the nut (14). Then lower the air vent to remove it.

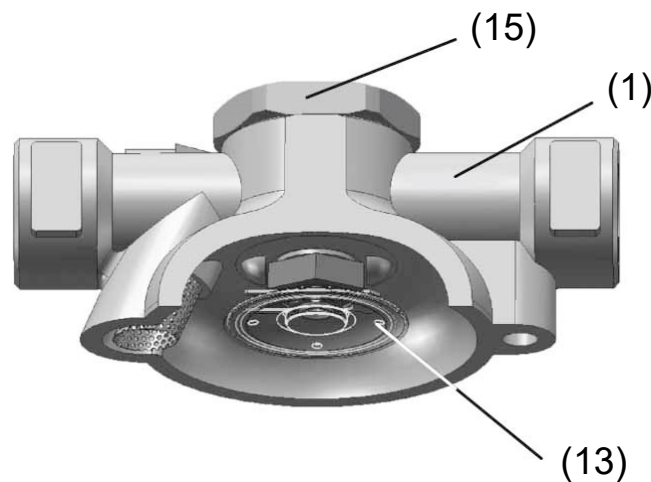

Disassembling the screen

- 1) Remove the screen plug (11)
- 2) Remove the screen (8) from the screen plug (11).

Repair the trap according to the instructions in Section 5 “Troubleshooting”.

After repairing the trap, reassemble the parts, reversing the order in which they were removed.

Reassembling the screen

- 1) Have thread sealing tape around the threads on the screen plug (11).
- 2) Put the screen (8) back on the screen plug (11).
- 3) Screw the screen plug (11) into the body (1), and then fasten the screen plug.

* Make sure that the head of the screen is mated with the body.

Reassembling the air vent

- 1) Install the seat gasket (5) on the air vent (13).
 - * To prevent seizure, apply a small amount of anti-seize lubricant to both sides of the seat gasket (5) and to the threads of the air vent (13).
- 2) Put the air vent (13) back into its correct position from the bottom of the body (1).
- 3) Fasten the air vent (13), from the air vent plug section on the upper side of the body (1), using the nut (14).
 - * Now, put the hexagonal air vent into the groove on the body to prevent the air vent from spinning free.
- 4) Fasten the air vent plug (15) onto the body (1).

Reassembling the trap

- 1) Attach the seat gasket (5) to the bottom cover (2).
 - * To prevent seizure, apply a small amount of anti-seize lubricant to both sides of the seat gasket (5) and to the threads of the valve seat.
- 2) Screw the valve seat (4) into the bottom cover (2), and tighten it.
- 3) Secure the bimetal (6) to the bottom cover (2) with the screw (7).
- 4) Put the cover gasket (9) and float (3) on the bottom cover (2), and attach them to the body (1). In this case, make sure that the body (1) and the bottom cover (2) are not in opposite directions to each other. Tighten the cover bolts (10) from the bottom cover (2) side.
 - * To prevent seizure, apply a small amount of anti-seize lubricant to the threads of the cover bolts (10).
 - * When tightening the cover bolts, tighten them evenly to prevent them from placing uneven pressure on the cover.
 - * The torque for each part is shown in the following table.

Parts	Tools	Across the flats	Torque
Valve seat (4)	Torque wrench	13 mm (0.51")	25N·m
Cover bolt (10)	Torque wrench	17 mm (0.67")	28N·m
Screen plug (11)	Torque wrench	24 mm (0.94")	25N·m
Nut (14)	Torque wrench	19 mm (0.75")	25N·m
Air vent plug (15)	Torque wrench	38 mm (1.50")	50N·m
Screw (7)	Torque screwdriver (Standard or Phillips)	-	0.3N·m

- * The cover gasket (9) should be replaced with a new one every time you disassemble the trap. When you remove the cover gasket (9) attached to the sealing surface, please pay attention that you do not damage the sealing surface.
- * The seat gasket (5), the screen plug gasket (12), or the air vent plug gasket (16) can be used repeatedly, but if the surface of the seat gasket (5) or air vent plug gasket (16) is damaged or distorted, please replace it with a new one.

G20N/G21N-F model

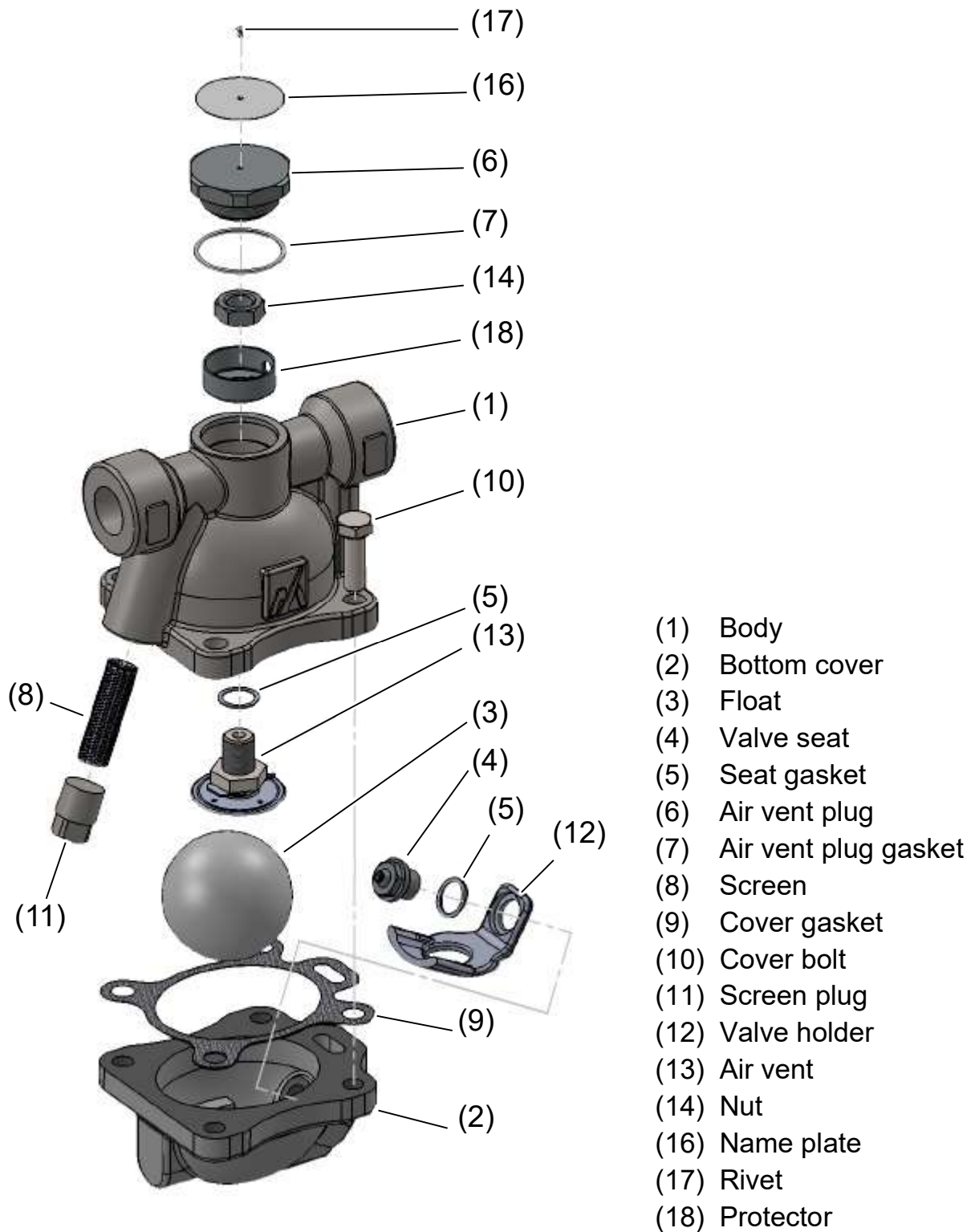

GC20 model

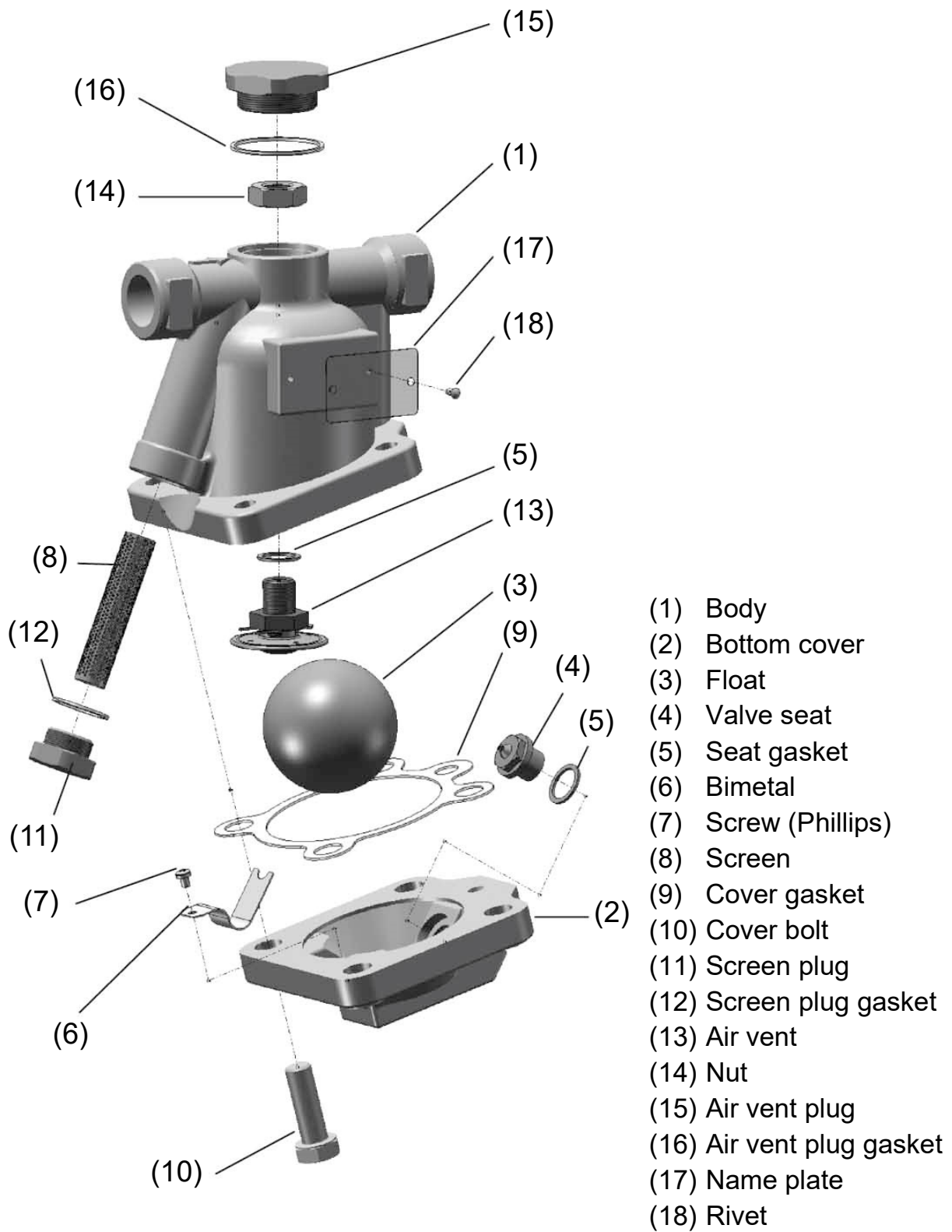

5 TROUBLESHOOTING

Problem		Possible cause	Solution	
Steam leaks or blows through.		Foreign material such as a scale or dirt is stuck to the valve or valve seat	Clean the valve or valve seat.	
		Foreign material such as a scale or dirt is stuck to the float seat of the valve holder. (only for the G20N/G21N-F)	Clean the valve holder.	
		Damage, wear or corrosion of the valve or valve seat	Replace the valve or valve seat.	
		The valve seat is loose.	Retighten the valve seat.*1	
		The float is damaged.	Replace the float.	
		The air vent is damaged.	Replace the air vent.	
		The nut is loose.	Retighten the nut.*2	
		Wrong installation position	Change the installation so that the air vent plug on the body of the trap is facing up.	
		Wrong installation direction	Make sure the arrow on the main body matches the flow direction of the fluid.	
		Damage or corrosion of the bimetal (only for the GC20)	Replace the bimetal.	
Steam leaks from the body	From between the body and body cover	The cover bolts are loose.	Retighten the cover bolt.*3	
		Damage, wear or corrosion of the cover gasket	Replace the cover gasket.	
		The gasket sealing surface on the body or bottom cover is damaged.	Replace the body with a new one, or replace the bottom cover.	
	From between the body and air vent plug/screen plug	The plug is loose.	Retighten the plug.*4	
		The gasket is damaged.	Replace the gasket.	
		The sealing surface on the body or plug is damaged. (Except the screen plug of the G20N/G21N-F)	Replace the body with a new one, or replace the bottom cover.	
		The thread sealing tape has deteriorated. (Only for the screen plug of the G20N/G21N-F)	Remove the deteriorated tape and rewrap it with a new one.	
	From between the body cover and plug (only for the G20N/G21N-F)	The plug is loose.	Retighten the plug.*4	
		The thread sealing tape has deteriorated.	Remove the deteriorated tape and rewrap it with a new one.	
		The body cover is damaged.	Replace the body cover.	
	Insufficient condensate is discharged, or no condensate is discharged.		The screen is clogged.	Clean the screen.
			Foreign material such as a scale or dirt is stuck to the float seat of the valve holder. (only for the G20N/G21N-F)	Clean the valve seat.
The bimetal is damaged. (only for the GC20)			Replace the bimetal.	
The air vent is damaged.			Replace the air vent.	
Wrong installation position			Change the installation so that the main body lies in a horizontal line.	
The steam pressure is over the specified maximum operating pressure.			Lower the pressure or replace the trap with one that has a higher maximum operating pressure.	
Insufficient condensate capacity			Replace the trap with a larger capacity trap.	

*1, *2, *3 and *4: Refer to the torque tables in Section 4, "Maintenance" to retighten the parts to the correct torque.

6 WARRANTY

6.1 Warranty period

The warranty period is 18 months after shipment or 12 months after installation, whichever occurs first.

6.2 Details of the warranty

If the product stops working correctly within the warranty period, we will repair or replace the product free of charge if the cause of the trouble is not one of the following items.

- 1) The precautions described in this manual were not observed
- 2) User's errors or mistakes such as an inappropriate installation or incorrect handling, or an excessively large impact caused by dropping
- 3) Problems caused by devices or equipment other than ours, or a disallowed use environment
- 4) When a repair or modification has been performed by anyone other than us or people who are authorized to make such repairs
- 5) Intrusion of salt or other substances that promote significant rust or corrosion or problems from fluids that contain the same substances
- 6) Consumable parts such as Packing, Gasket, O-ring, Diaphragm, etc
- 7) Attachment or accumulation of foreign matter in the pipe, such as dust and scale
- 8) Problems from fires, natural disasters, or other force majeure which is not our responsibility

6.3 Warranty limitation

The remedy available under the warranty shall not exceed the sales price of the products delivered, for any cause whatsoever.

7 SERIAL NUMBER (S. No.) DESIGNATION

The following 4-digit or 9-digit “S.No.” is displayed on the product.

- For 4-digit display

S.No. □□□□

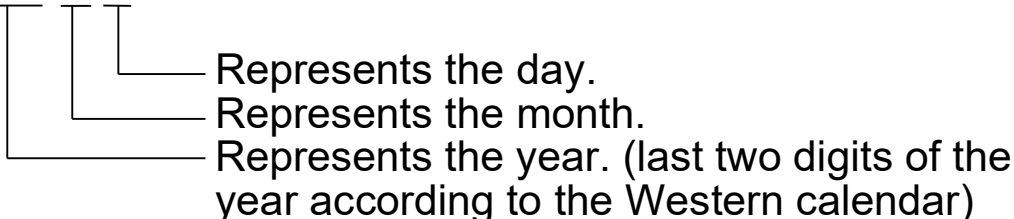

Example of serial number designation

1 7 1 1 → Jan.1, 2017

2 9 X M → Oct. 21, 2029

- For 9-digit display

S.No. □□□□□□□□□

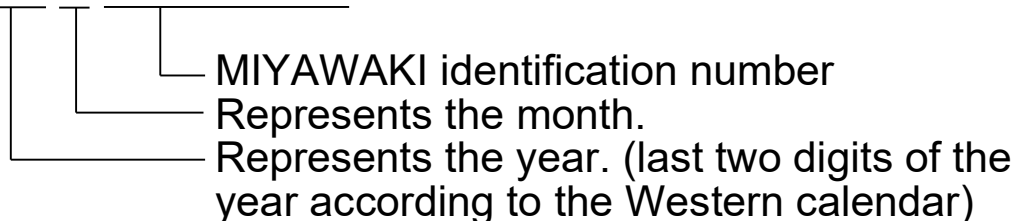

Example of serial number designation

1 7 1 1 2 C 0 2 0 → Jan., 2017

2 9 X 0 5 M 0 5 0 → Oct., 2029

Month designation system

Month	1	2	3	4	5	6	7	8	9	10	11	12
Symbol	1	2	3	4	5	6	7	8	9	X	Y	Z

Day designation system

Day	1	2	3	4	5	6	7	8	9	10	11	12
Symbol	1	2	3	4	5	6	7	8	9	A	B	C

Day	13	14	15	16	17	18	19	20	21	22	23	24
Symbol	D	E	F	G	H	J	K	L	M	N	O	P

Day	25	26	27	28	29	30	31
Symbol	Q	R	S	T	U	V	W

8 GUIDANCE FOR READING SPECIAL PRODUCT NAME

○○○-○○-□

Special symbol:
Symbol apply only to special product
(Please refer to table 1 for details)
 English letter after “-“

Model symbol:
Product model number

Table 1 Symbol description

Suffix	Special contents
A	Trap for high-pressure gas installed property (only for Gas Trap)
C	Blow valve attached
K	Change of gasket
L	Special face to face dimension
M	Change of parts material
P, T	Change of operating pressure, temperature, condensate capacity, etc
R	Change of screen mesh
V	Change of air vent
X	Other than mentioned above or complex of special contents above

-
- For any questions about the product that you purchased or about the details in this user's manual, please contact the following.
 - © 2017 MIYAWAKI INC.
This user's manual may not be reproduced or copied in whole or in part, without the written consent of MIYAWAKI INC.
 - Some special specifications of the product may found to be different from the ones in the user's manual. If you have any question, please contact MIYAWAKI, our local authorized agent, or the company where you purchased the product.
 - In the interest of the development and improvement of our products, MIYAWAKI Inc. reserves the right to change the specification of the products without prior notice.
-



If you need any assistance regarding this manual, please contact MIYAWAKI INC.'s International Sales Dept. or its local representative. By scanning QR Code, you can access inquiry form.



INTERNATIONAL SALES DEPT.

2-1-30, Tagawakita, Yodogawa-ku, Osaka, 532-0021, Japan

Tel: +81-6-6302-5549

www.miyawaki-inc.com/en e-mail: export@miyawaki-inc.co.jp

EU Importer and Authorized representative:



Birnbaumsmühle 65, 15234 Frankfurt (Oder), Germany

Tel: +49-335-4007-0097

www.miyawaki.de e-mail: info@miyawaki.de

China Importer and Authorized representative:



Room 902, Building 8, Huaqing Chuangzhi Park, No.3 Qingyan Road, Huishan District, Wuxi City Jiangsu Province, China

Tel: +86-510-8359-5125

www.miyawaki-inc.com.cn e-mail: mywkwest@miyawaki-inc.com.cn

808052-06 2403

G20N/G21N-F/GC20