

THERMODYNAMIC STEAM TRAP

SC, SF

USER'S MANUAL



 **MIYAWAKI INC.**

SAFETY GUIDE

The models SC and SF are cast iron disc-type steam traps for medium up to large condensate loads.
In order to get maximum benefit from this product, be sure to read this manual before installing it.

The following warnings and cautions are shown at appropriate places in this manual.



Failure to observe this type of precaution may lead to serious injury or death.



Failure to follow this type of precaution can lead to injury or damage to equipment and property.

Table of Contents

| | | |
|---|---|----|
| 1 | SPECIFICATIONS AND MARKINGS | 1 |
| 2 | CONSTRUCTION DETAILS | 2 |
| 3 | INSTALLATION | 3 |
| 4 | OPERATION | 4 |
| 5 | MAINTENANCE | 5 |
| 6 | TROUBLESHOOTING | 8 |
| 7 | WARRANTY | 9 |
| 8 | SERIAL NUMBER (S. No.) DESIGNATION | 10 |
| 9 | GUIDANCE FOR READING SPECIAL PRODUCT NAME | 11 |

1 SPECIFICATIONS AND MARKINGS



WARNING

Be sure not to use this product at higher pressures than the specified maximum allowable pressure (PMA) or at temperatures higher than the specified maximum allowable temperature (TMA).

Check the following items to avoid misuse of the product.

- 1) Maximum allowable pressure (PMA): 1.6 MPa (232 psig)
 - 2) Maximum allowable temperature (TMA): 220 °C (428 °F)
 - 3) Maximum Operating pressure (PMO): 1.6 MPa (232 psig)
(Shown as MAX.P. on the name plate)
 - 4) Maximum operating temperature (TMO): 220 °C (428 °F)
(Shown as MAX.T. on the name plate)
 - 5) Size: 20 mm (3/4"), 25 mm (1")
 - 6) Year of production: The two leftmost digits in the four-digit or nine-digit 'S No.' on the name plate are the last two digits of the year of production.
 - 7) Flow direction: Shown by an arrow
 - 8) Body material: Cast iron FC250
 - 9) Model symbol: Showing the product model name
- Some pictures and illustrations in this manual are examples of the models SC and SF. For more details regarding dimensions and other specifications, please refer to the catalog.

The models SC and SF fully comply with the requirements of the European Pressure Equipment Directive 2014/68/EU. They are classified according to Article 4, Section 3 of the PED, which does not allow to bear the CE marking.

2 CONSTRUCTION DETAILS

Model SC-310 and SC-311

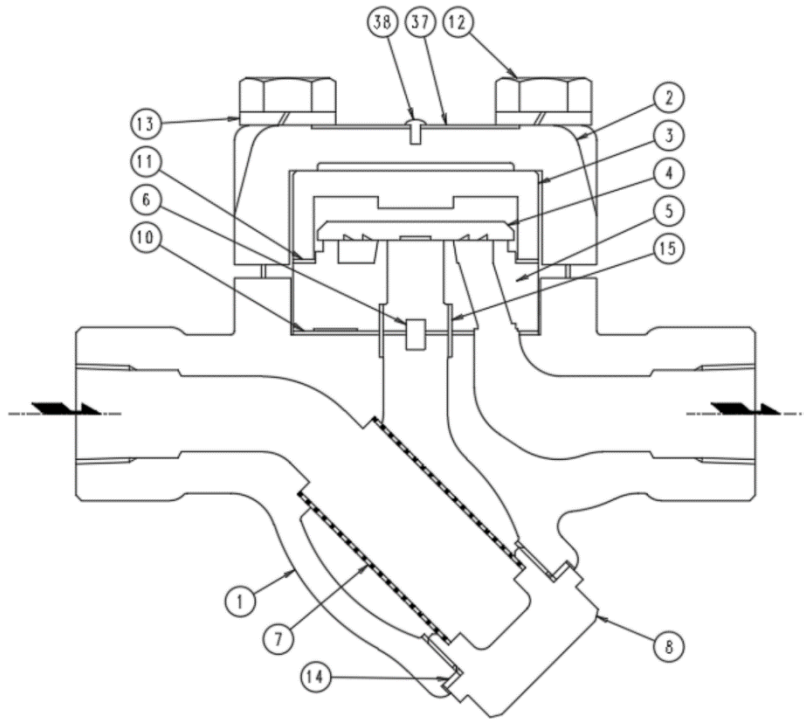

Model SF-340 and SF-341

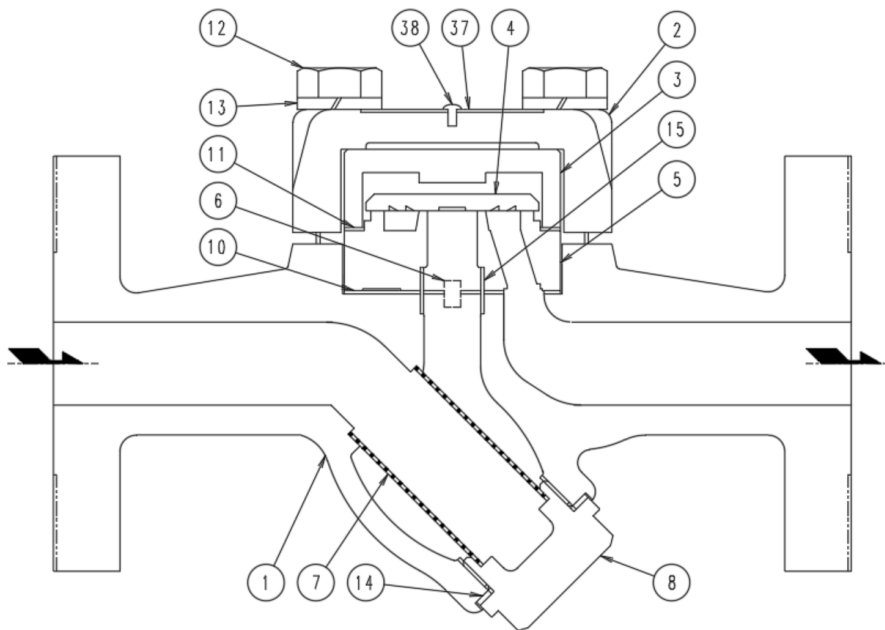

- | | |
|-----------|-----------------|
| 1. Body | 10. Seat Gasket |
| 2. Cover | 11. Cap Gasket |
| 3. Cap | 12. Cover Bolt |
| 4. Disc | 13. Washer |
| 5. Seat | 14. Plug Gasket |
| 6. Pin | 15. Pipe |
| 7. Screen | 37. Name Plate |
| 8. Plug | 38. Rivet |

3 INSTALLATION



WARNING

Pay very careful attention when working in hazardous environments. There is a risk of explosion and the possibility of dangerous gases leaking. Always check whether the pipeline contains flammable, high pressure or high temperature materials before starting to work.

- Make sure that isolation valves are installed on both the upstream and downstream lines.



CAUTION

Before installing the product, open both isolation valves and the bypass valve, if one exists, to blow out any debris or dirt inside the pipeline. After blowing out the line, before starting to work, close the isolation valves and allow time for the temperature to drop to a safe working temperature.

When installing the product, be sure to leave clearance for maintaining it.

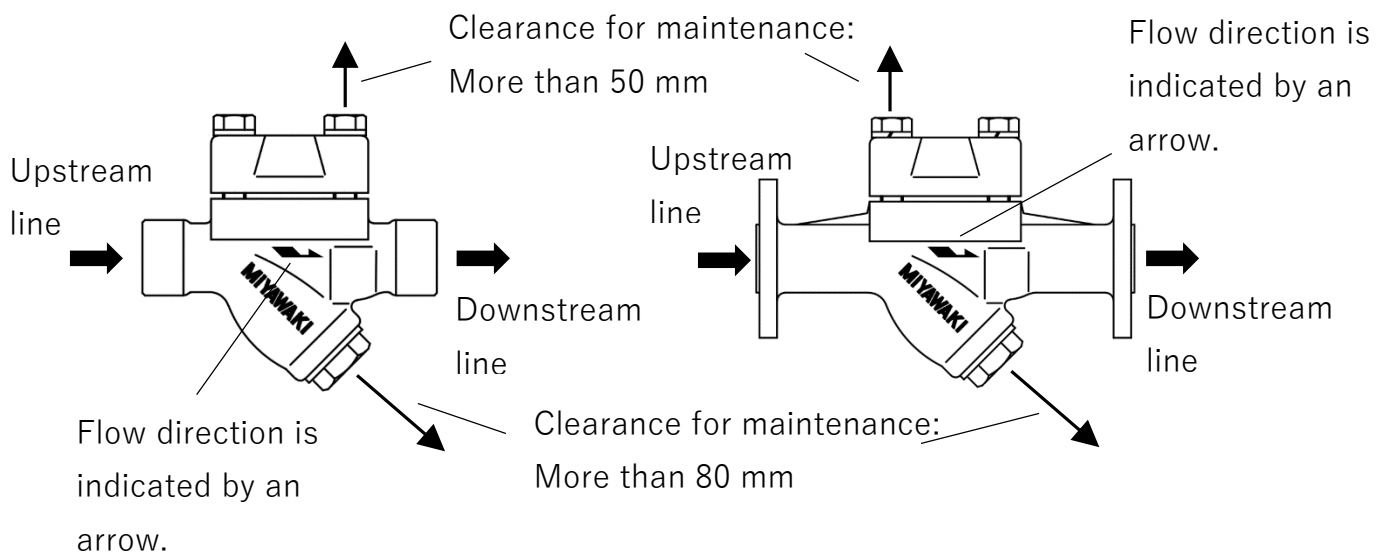

- 1) Remove the dustproof seals covering both connections.
※Products shipped in plastic bags may not have dustproof seals.
- 2) Check the flow direction indicated on the side of the body.
- 3) The models SC and SF can be used for both horizontal and vertical lines. However, when installing these models in a horizontal line, be sure to maintain a slight slope to the line, so that any condensate will flow smoothly.
- 4) Open the isolation valve on the upstream line and make sure the product works normally.

4 OPERATION



CAUTION

Before starting operation, open the bypass valve or blow valve completely and blow off the scale in the piping.

4.1 Operation procedure

- 1) After blowing off the scale from the piping, close the bypass valve or blow valve.
- 2) Open the stop valve on the trap outlet side.
- 3) Open the stop valve on the trap inlet side.

4.2 Stop procedure

- 1) Close the stop valve on the trap inlet side.
- 2) Close the stop valve on the trap outlet side.

* When stopping for a long time, completely drain the condensate from the piping and trap and close the valves before and after the trap.

5 MAINTENANCE



WARNING

- Before removing the trap from the pipe or disassembling it, be sure to close the isolation valves. Then, release the residual pressure from the trap body (make sure that the pressure in the main body is equal to the atmospheric pressure). After it has fully cooled down (after the temperature of the main body has reached ambient temperature), confirm for safe conditions and then begin work.
- Even when the isolation valves are closed, there may be residual internal pressure due to leaks from the isolation valves. Therefore, be very careful.



CAUTION

- When replacing parts, make sure the replacement parts are supplied by MIYAWAKI.

The performance of steam traps deteriorates gradually over time due to wear, corrosion or dirt accumulating around the valve and the valve seat. Please conduct periodic diagnosis of traps in order to keep steam control systems and equipment working well.

5.1 Tools for Diagnosing Steam Traps

■ Dr. Trap

Dr. Trap is a sophisticated steam trap management system for diagnosing steam traps automatically by measuring the vibration and temperature of the steam trap. Survey results are stored in the testing equipment and transferred to a steam trap analysis software. The software aggregates and analyses steam trap survey data, identifying faulty steam traps, providing steam loss and financial loss data, estimating CO₂ emissions corresponding to leaking steam traps and providing many other analyze possibilities to manage the steam trap population easily.

■ Dr. Trap Jr.

Dr. Trap Jr. is an inexpensive and easily to handle steam trap diagnostic system consisting of an ultrasonic checker, temperature probe and a sophisticated analysis software. The software allows to determine the condition of a steam trap, to estimate steam and financial losses and the related CO₂ emissions.

For more details, please, check our homepage:

<https://www.miyawaki.net/en/products/steam-trap-management-system>

or ask our local representative.

5.2 Repairs

When a trap fails, it is necessary to clean the internal parts and to replace damaged parts. Take the failed trap apart following the steps below.

5.2.1 Disassembling the trap

- 1) Turn the plug (8) counterclockwise to remove it. Remove also the plug gasket (14).
- 2) Remove the screen (7).
- 3) Untighten the four cover bolts (12) and remove the bolts and washers (13). Then take off the cover (2).
- 4) Remove the cap (3), and take out the disc (4), the seat (5), the gaskets (10) and (11) and the pipe (15).
- 5) Clean and check all parts. Replace any parts that are worn or damaged. If the seat (5) or disc (4) are worn, please, replace the complete inner unit.

After cleaning the trap and replacing damaged parts, reassemble the parts in reverse order as follows.

5.2.2 Reassembling the trap

- 1) Put the screen (7) and the plug gasket (14) back on the plug (8).
- 2) Then tighten the plug (8).
- 3) Put the seat gasket (10) into the body (1), so that the pin (6) fits into the hole of the seat gasket (10). Then put the seat (5) back so that the pin (6) is inserted into the hole of the seat (5).
- 4) Put the disc (4) on the seat (5).
- 5) Put the cap gasket (11) on the seat (5) and place the cap (3) over the seat (5).
- 6) Put the cover (2) on the body (1) and tighten the cover bolts (12). Do not forget the washers (13) for the cover bolts (12).

Torque table

| Parts | Tools | Across the flats | Torque |
|-----------------|---------------|------------------|---------|
| Cover Bolt (12) | Torque wrench | 22 mm (0.87") | 70 N·m |
| Plug (8) | Torque wrench | 35 mm (1.38") | 100 N·m |



CAUTION

When reassembling always replace the gaskets (10, 11 and 14) with new ones. Tighten the cover bolts (12) evenly crosswise.

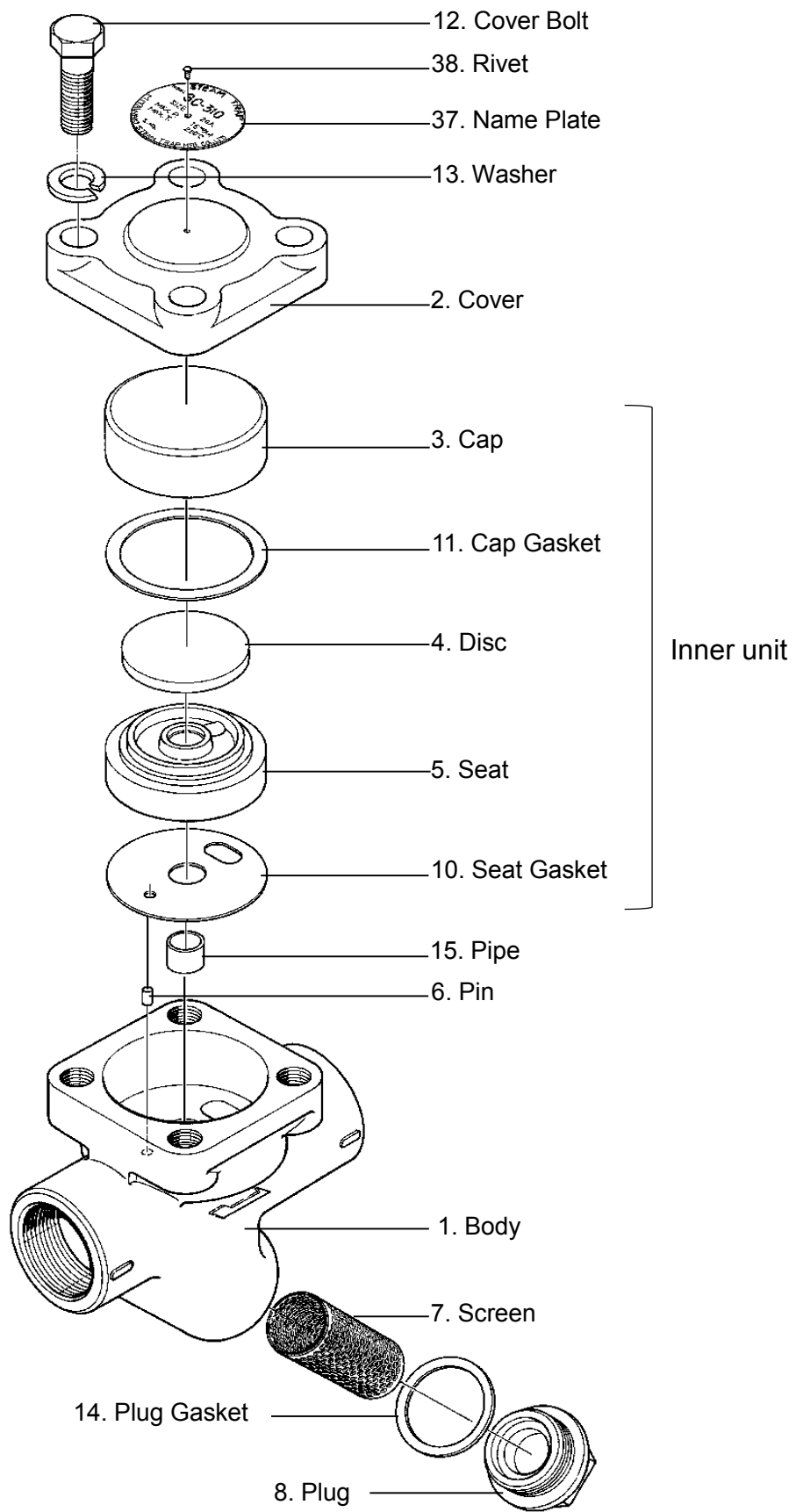

6 TROUBLESHOOTING

| Problem | | Possible cause | Solution |
|--|---|---|--|
| Steam leaks or blows through. | | Dirt is stuck around the disc (4) or the seat (5). | Clean the disc (4) and the seat (5). |
| | | Damage, wear or corrosion of the disc (4) | Replace the inner unit. |
| | | Damage, wear or corrosion of the seat (5). | Replace the inner unit. |
| | | The seat gasket (10) is damaged. | Replace the seat gasket (10). |
| | | The back pressure is too high. (The back pressure must be less than 50% of the inlet pressure.) | Replace the trap with an appropriate trap. |
| Steam leaks from the body. | From the cap connection | The cover bolts (12) are loose. | Tighten the cover bolts (12). |
| | | The cap gasket (11) is damaged. | Replace the cap gasket (11). |
| | | The seat gasket (10) is damaged. | Replace the seat gasket (10). |
| | | The sealing surface of the body (1), seat (5) or cap (3) is damaged. | Replace the damaged part. |
| | | The plug (8) is loose. | Tighten the plug (8). |
| | From the plug connection | The plug gasket (14) is damaged. | Replace the plug gasket (14). |
| | | The sealing surface of the body (1) or plug (8) is damaged. | Replace the damaged part. |
| | Insufficient condensate discharged, or no condensate discharged. | | The screen (7) is clogged. |
| Dirt has built up around the seat (5). | | | Clean the seat (5). |
| Dirt has built up in the fluid path inside the body (1). | | | Clean the body (1). |
| Insufficient condensate capacity. | | | Replace with a trap with higher capacity. |

Refer to the torque table in Section 5 "Maintenance" to retighten the parts with the correct torque.

7 WARRANTY

7.1 Warranty period

The warranty period is 18 months after shipment or 12 months after installation, whichever occurs first.

7.2 Details of the warranty

If the product stops working correctly within the warranty period, we will repair or replace the product free of charge if the cause of the trouble is not one of the following items.

- 1) The precautions described in this manual were not observed.
- 2) User's errors or mistakes such as an inappropriate installation or incorrect handling, or an excessively large impact caused by dropping
- 3) Problems caused by devices or equipment other than MIYAWAKI's, or a disallowed use environment
- 4) When a repair or modification has been performed by anyone other than MIYAWAKI or people who are authorized to make such repairs
- 5) Intrusion of salt or other substances that promote significant rust or corrosion or problems from fluids that contain the same substances
- 6) Consumable parts such as Packing, Gasket, O-ring, Diaphragm, etc.
- 7) Attachment or accumulation of foreign matter in the pipe, such as dust and scale
- 8) Problems from fires, natural disasters, or other force majeure which is not MIYAWAKI's responsibility

7.3 Warranty limitation

The remedy available under the warranty shall not exceed the sales price of the products delivered, for any cause whatsoever.

8 SERIAL NUMBER (S. No.) DESIGNATION

The following 4-digit or 9-digit 'S. No.' is displayed on the product.

- For 4-digit display

S.No. □□□□

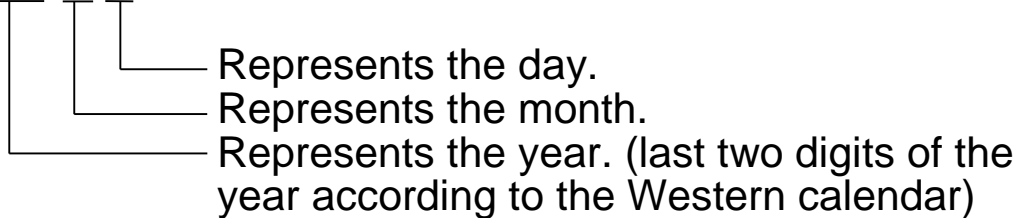

Example of serial number designation

1 7 1 1 → Jan.1, 2017

2 9 X M → Oct. 21, 2029

- For 9-digit display

S.No. □□□□□□□□□

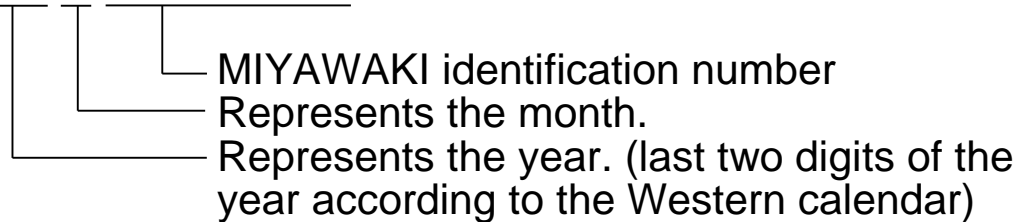

Example of serial number designation

1 7 1 1 2 C 0 2 0 → Jan., 2017

2 9 X 0 5 M 0 5 0 → Oct., 2029

Month designation system

| | | | | | | | | | | | | |
|--------|---|---|---|---|---|---|---|---|---|----|----|----|
| Month | 1 | 2 | 3 | 4 | 5 | 6 | 7 | 8 | 9 | 10 | 11 | 12 |
| Symbol | 1 | 2 | 3 | 4 | 5 | 6 | 7 | 8 | 9 | X | Y | Z |

Day designation system

| | | | | | | | | | | | | |
|--------|---|---|---|---|---|---|---|---|---|----|----|----|
| Day | 1 | 2 | 3 | 4 | 5 | 6 | 7 | 8 | 9 | 10 | 11 | 12 |
| Symbol | 1 | 2 | 3 | 4 | 5 | 6 | 7 | 8 | 9 | A | B | C |

| | | | | | | | | | | | | |
|--------|----|----|----|----|----|----|----|----|----|----|----|----|
| Day | 13 | 14 | 15 | 16 | 17 | 18 | 19 | 20 | 21 | 22 | 23 | 24 |
| Symbol | D | E | F | G | H | J | K | L | M | N | O | P |

| | | | | | | | |
|--------|----|----|----|----|----|----|----|
| Day | 25 | 26 | 27 | 28 | 29 | 30 | 31 |
| Symbol | Q | R | S | T | U | V | W |

9 GUIDANCE FOR READING SPECIAL PRODUCT NAME

○○○-○○-□

Special symbol:
The symbol applies only to special products.
(Please refer to table 1 for details)

Model symbol:
Product model number

Table 1 Symbol description

| Suffix | Special contents |
|--------|--|
| A | Trap for high-pressure gas installed property (only for Gas Trap) |
| C | Blow valve attached |
| K | Change of gasket |
| L | Special face to face dimension |
| M | Change of parts material |
| P, T | Change of operating pressure, temperature, condensate capacity, etc. |
| R | Change of screen mesh |
| V | Change of air vent |
| X | Other than mentioned above or complex of special contents above |

-
- お買い上げの製品及びこの取扱説明書内容についてのご質問・お問い合わせ、またこの取扱説明書を紛失したり、汚損により読めなくなった場合の資料等のご請求は、お買い上げ頂いた販売店もしくは最寄の弊社ミヤワキへご連絡ください。
 - 特殊仕様の製品については、取扱説明書の内容と一部異なる場合があります。特殊仕様に関する取扱説明書内容についてのご質問は、お買い上げ頂いた販売店もしくは最寄の弊社ミヤワキまでお問い合わせください。

- © 2020 MIYAWAKI INC.
This user's manual may not be reproduced or copied in whole or in part, without the written consent of MIYAWAKI INC.
 - Some special specifications of the product you have, may found to be different from the ones in the user's manual. If you have any question, please contact MIYAWAKI, our local authorized agent, or the company where you purchased the product.
 - In the interest of the development and improvement of our products, MIYAWAKI Inc. reserves the right to change the specification of the products without prior notice.
-

お問い合わせ窓口

製品の使い方やアフターサポートなど、製品に関するお問い合わせは、右のQRコードから、最寄りの弊社事業所までご連絡ください。弊社事業所一覧(連絡先)は右のQRコードをスマートフォン、携帯電話等で読み取っていただくことでアクセスできます。



本社・工場

〒532-0021 大阪市淀川区田川北 2-1-30

Tel : 06-6302-5531(代)

www.miyawaki-inc.com



INTERNATIONAL SALES DEPT.

2-1-30, Tagawakita, Yodogawa-ku, Osaka, 532-0021, Japan

Tel: +81-6-6302-5549

www.miyawaki.net e-mail: export@miyawaki-inc.co.jp

EU Importer and Authorized representative:



MIYAWAKI GmbH

Birnbaumsmühle 65, 15234 Frankfurt (Oder), Germany

Tel: +49-335-4007-0097

www.miyawaki.net e-mail: info@miyawaki.de

China Importer and Authorized representative:



MIYAWAKI WEST Co., Ltd.

Room 1705, No.1, Building No.311, Yanxin Road, Huishan Economic Development Zone, Wuxi, Jiangsu, China

Tel: +86-510-8359-5125

www.miyawaki-inc.com.cn e-mail: mywkwest@miyawaki-inc.com.cn

808080-01 2010

SC, SF