

OPERATION MANUAL

FOR

SEPARATOR

MODEL:H5 / H5F



SAFETY

The following warnings and cautions are shown at appropriate places in this manual.



WARNING

Failure to observe this type of precaution may lead to serious injury or death.



CAUTION

Failure to follow this type of precaution can lead to injury or damage to equipment and property.

S No. on the name plate of our product indicates a manufacturing date.

The following 4-digit or 9-digit 'S.No.' is displayed on the product.

●For 4-digit display

S.No. □□□□

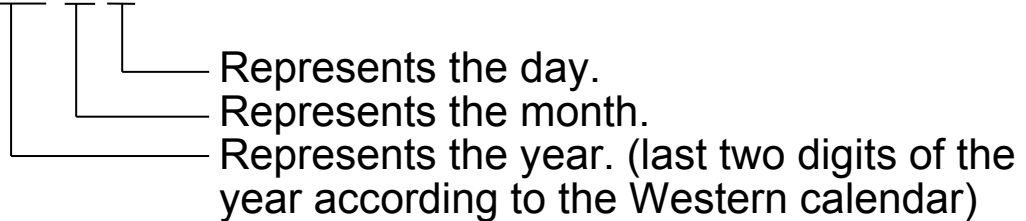

Example of serial number designation
 17 1 1 → Jan 1, 2017
 29XM → Oct 21, 2029

●For 9-digit display

S.No. □□□□□□□□□

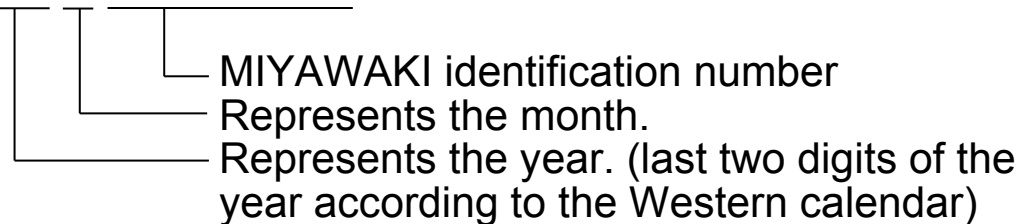

Example of serial number designation
 17 1 1 2 C 0 2 0 → Jan , 2017
 29 X 0 5 M 0 5 0 → Oct , 2029

Month designation system

Month	1	2	3	4	5	6	7	8	9	10	11	12
Symbol	1	2	3	4	5	6	7	8	9	X	Y	Z

Day designation system

Day	1	2	3	4	5	6	7	8	9	10	11	12
Symbol	1	2	3	4	5	6	7	8	9	A	B	C

Day	13	14	15	16	17	18	19	20	21	22	23	24
Symbol	D	E	F	G	H	J	K	L	M	N	O	P

Day	25	26	27	28	29	30	31
Symbol	Q	R	S	T	U	V	W

CONTENTS

1. Introduction..... P.1
2. Dimensions and Specifications.....P.1
3. Installations.....P.2
4. Maintenance, Disassembling and Assembling.....P.2
5. Construction..... P.3
6. Warranty..... P.4
- ★ Guidance for reading special product name.....P.5

1. Introduction

Drain Separator Model H5/H5F a device that separates, removes the drain generated in the steam piping, and supplies good quality dry steam. The separation power doesn't decrease even if the load changes by tornado method (centrifuge type) adoption. It is possible to use it by the compact design type as a separator for air. This manual contains Installation, Trouble Shooting, Maintenance etc.. Never fail to read them to the end before using.

2. Dimensions and Specifications

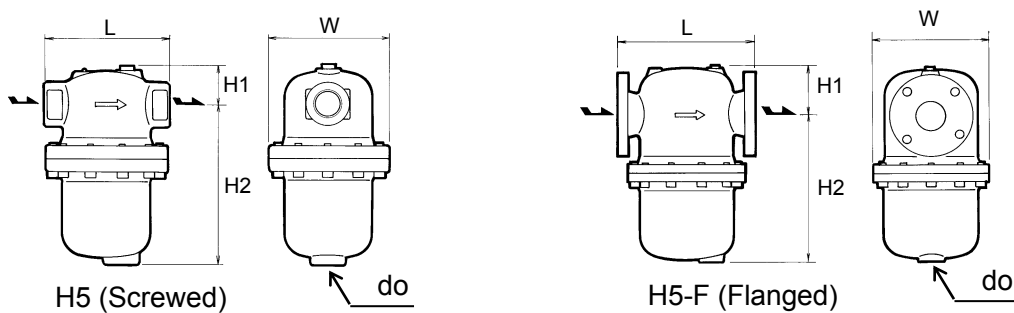

Model No.	Connection	Size mm (inch)	Maximum Operating Pressure(MPa)	Maximum Temperature °C(°F)	Material of Body	Dimensions (mm)					Weight (kg)						
						L	H1	H2	W	do							
H5	Screwed	15(1/2)	2.0 (For Air : 0.97)	220 (428)	Ductile Cast Iron (FCD450)	150	50	193	146	Rc	7.1						
		20(3/4)								20							
		25(1)				Rc	12.5										
		32(1-1/4)						190	69	213	175						
		40(1-1/2)						219	82	260	199	25	20.5				
50(2)	292	104	314	248	40.0												
H5-F	Flanged	65(2-1/2)															
		80(3)										343	123	361	283	Rc	56.0
		100(4)										402	149	445	341	32	100.0

3. Installations

 CAUTIONS	<ul style="list-style-type: none"> ● Before installing the trap always blow off the slugges, scales, etc. from the piping. ● Separator can be installed horizontally.
---	---

- 1) Be sure to install a trap device below the drain discharge port.
- 2) The top end of the trap should be lower than the drain discharge port of Separator.

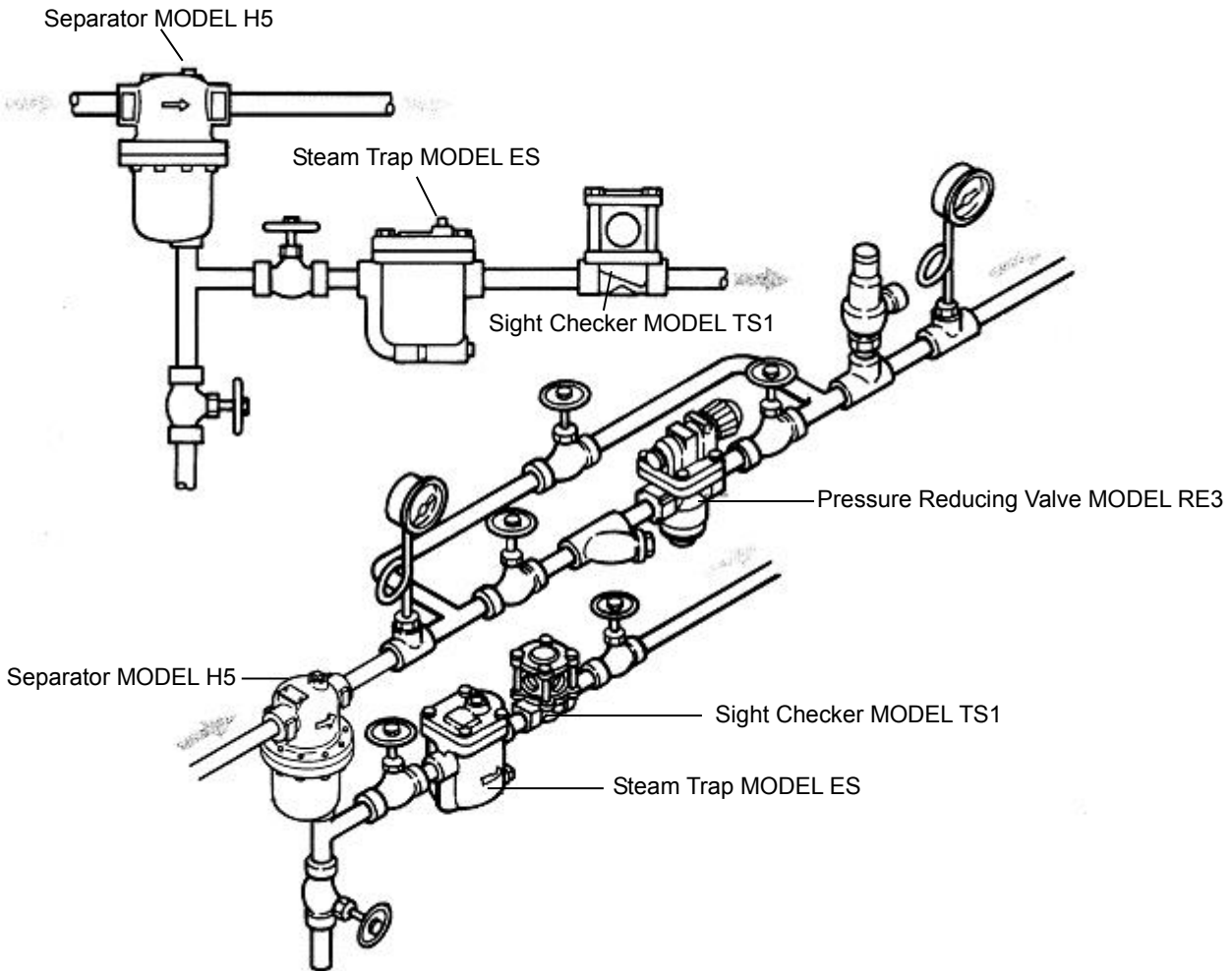

4. Maintenance, Disassembling and Assembling

 WARNING	<p>When disassembling a hot trap, be sure to release the pressure inside to atmospheric pressure, and cool the trap before the work.</p>
--	--

- 1) Dismantle the Cover Bolt(5), take off Receiver(2).
will come with the Cover(2).
- 2) Clean and check Body(1) internal, Receiver(2), and Nozzle(3).
Assemble in the opposite way of disassembling.

 CAUTIONS	<ul style="list-style-type: none"> ● Also Bolt(5) should be tightened evenly. ● When reassembling always replace the Gasket(4) to new one.
---	--

5. Construction

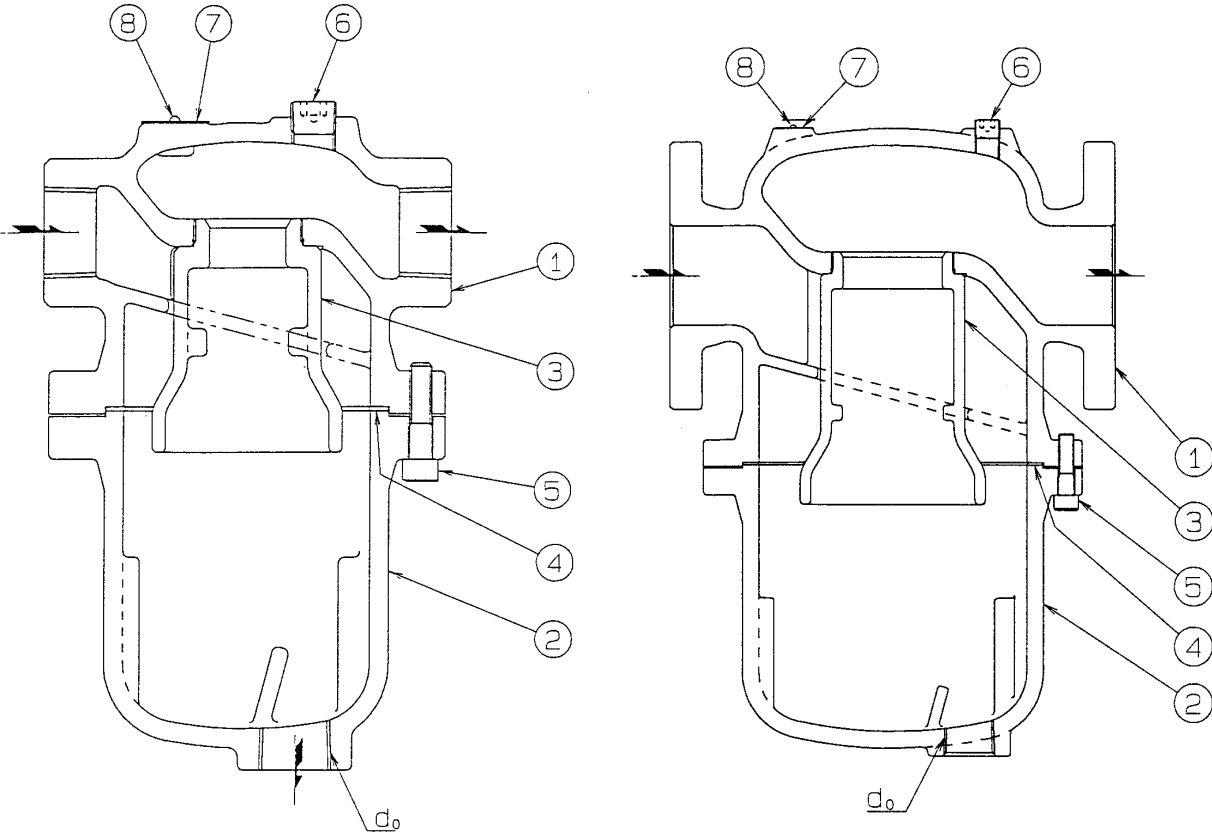

- 1.Body
- 2.Reciver
- 3.Nozzle
- 4.Gasket
- 5.Bolt
- 6.Plug
- 7. Name Plate
- 8.Rivet

6 Warranty

6.1 Warranty period

The warranty period is 18 months after shipment or 12 months after installation, whichever occurs first.

6.2 Details of the warranty

If the product stops working correctly within the warranty period, we will repair or replace the product free of charge if the cause of the trouble is not one of the following items.

- 1) The precautions described in this manual were not observed
- 2) User's errors or mistakes such as an inappropriate installation or incorrect handling, or an excessively large impact caused by dropping
- 3) Problems caused by devices or equipment other than ours, or a disallowed use environment
- 4) When a repair or modification has been performed by anyone other than us or people who are authorized to make such repairs
- 5) Intrusion of salt or other substances that promote significant rust or corrosion or problems from fluids that contain the same substances
- 6) Consumable parts such as Packing, Gasket, O-ring, Diaphragm, etc
- 7) Attachment or accumulation of foreign matter in the pipe, such as dust and scale
- 8) Problems from fires, natural disasters, or other force majeure which is not our responsibility

6.3 Warranty limitation

The remedy available under the warranty shall not exceed the sales price of the products delivered, for any cause whatsoever.

★ Guidance for reading special product name

○○○-○○-□

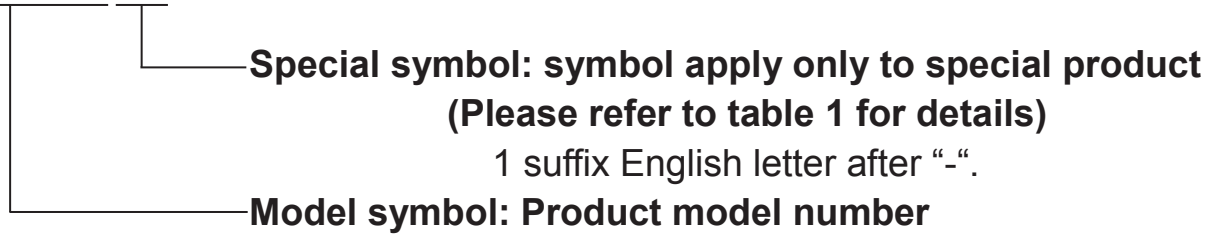

Table 1 Symbol description

Suffix	Special contents
A	Approved high-pressure gas trap
C	Blow valve attached & countermeasure against scale
K	Change of gasket
L	Special face to face dimension
M	Change of parts material
P	Change of operating pressure
R	Change of screen mesh or countermeasure against scale
T	Parts are standards, and the specification (operating temp, press. etc.) is changed
V	Change of air vent
X	Other than mentioned above or complex of special contents above

お問い合わせ窓口

製品の使い方やアフターサポートなど、製品に関するお問い合わせは、右のQRコードから、最寄りの弊社事業所までご連絡ください。弊社事業所一覧(連絡先)は右のQRコードをスマートフォン、携帯電話等で読み取っていただくことでアクセスできます。



本社・工場

〒532-0021 大阪市淀川区田川北 2-1-30

Tel : 06-6302-5531(代)

www.miyawaki-inc.com



INTERNATIONAL SALES DEPT.

2-1-30, Tagawakita, Yodogawa-ku, Osaka, 532-0021, Japan

Tel: +81-6-6302-5549

www.miyawaki-inc.com/en e-mail: export@miyawaki-inc.co.jp

EU Importer and Authorized representative:



Birnbaumsmühle 65, 15234 Frankfurt (Oder), Germany

Tel: +49-335-4007-0097

www.miyawaki.de e-mail: info@miyawaki.de

China Importer and Authorized representative:



Room 1705, No.1, Building, No.311, Yanxin Road, Huishan Economic Development Zone, Wuxi, Jiangsu, China

Tel: +86-510-8359-5125

www.miyawaki-inc.com.cn e-mail: mykwkwest@miyawaki-inc.com.cn