

INLINE MIXER

# DMX-N

---

USER'S MANUAL

# SAFETY GUIDE

The model DMX-N inline mixer is designed to smoothly mix the condensate discharged from a steam trap in a steam piping system with the condensate in a condensate collection pipe in order to smoothly collect the condensate.

In order to get maximum benefit from this product, be sure to read this manual before installing it.

The following warnings and cautions are shown at appropriate places in this manual.



Failure to observe this type of precaution may lead to serious injury or death.



Failure to follow this type of precaution can lead to injury or damage to equipment and property.

## Table of Contents

---

1	SPECIFICATIONS AND MARKINGS	1
2	CONSTRUCTION DETAILS	2
3	INSTALLATION	3
4	WARRANTY	4
5	SERIAL NUMBER (S. No.) DESIGNATION	5
6	GUIDANCE FOR READING SPECIAL PRODUCT NAME	6

# 1 SPECIFICATIONS AND MARKINGS



## WARNING

Be sure not to use this product at higher pressures than the specified maximum allowable pressure (PMA) or at temperatures higher than the specified maximum allowable temperature (TMA).

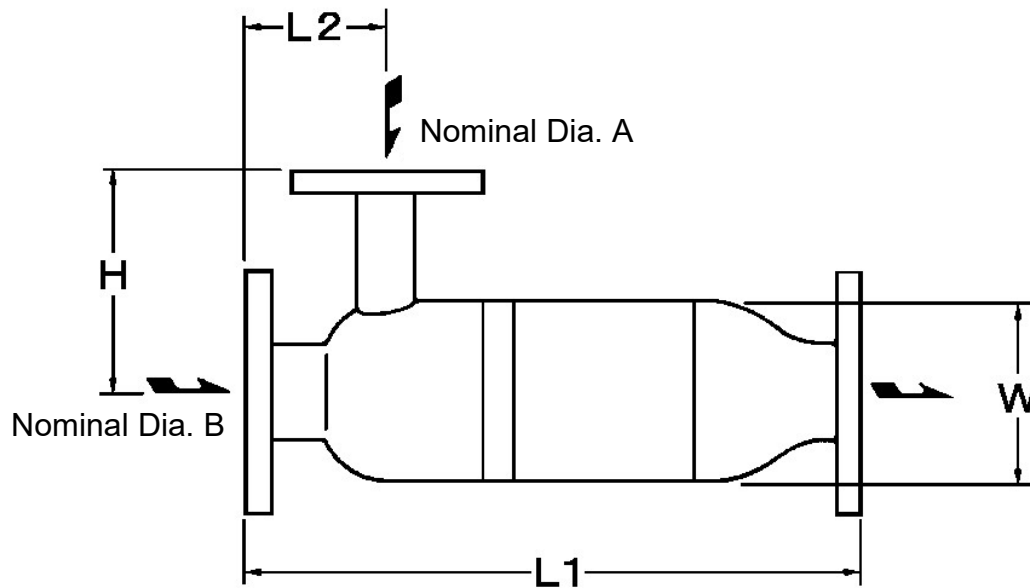

Model	Connection type	Nominal dia. (mm)	Maximum operating pressure (MPa)	Minimum operating pressure differential (MPa)	Maximum operating temperature (°C)	Body material	Dimensions (mm)				Weight (kg)			
							Type	A × B	L1	L2		H	W	
DMX-N	Flanged JIS10K (FF, RF)	20 × 20	1.0	0.05	185	Body Carbon steel (STPG370)	350	80	100	61	5.0			
		20 × 25								76	7.0			
		25 × 25								89	10.0			
		20 × 32												
		25 × 32												
		32 × 32								400	90	140	114	11.5
		20 × 40												
		25 × 40												
		32 × 40												
		20 × 50												
		25 × 50												
32 × 50	12.5													

Pressure conversion: MPa = 10.197 kgf/cm<sup>2</sup>

- Minimum operating pressure differential is the minimum value of the difference (P1 - P2) between the pressure (P1) of the condensate discharged from the steam trap and that (P2) of the condensate in the collection pipe.
- Model symbol: Showing the product model name

## 2 CONSTRUCTION DETAILS

---

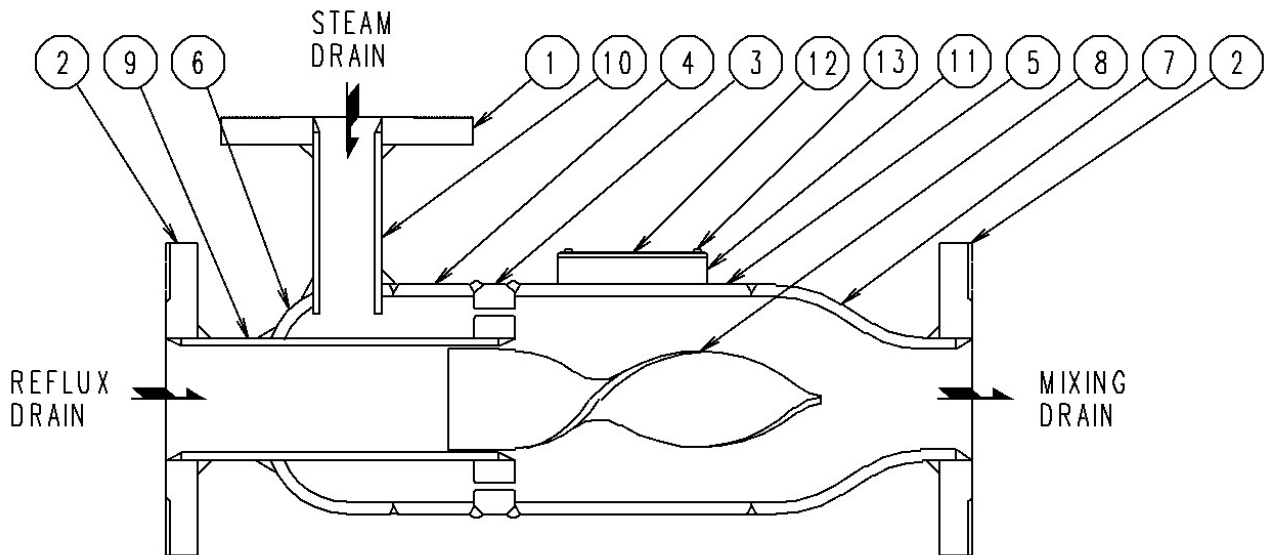

- |            |                |
|------------|----------------|
| 1. Flange  | 8. Screw       |
| 2. Flange  | 9. Pipe        |
| 3. Plate   | 10. Pipe       |
| 4. Pipe    | 11. Name Base  |
| 5. Pipe    | 12. Name Plate |
| 6. Cap     | 13. Rivet      |
| 7. Reducer |                |

### 3 INSTALLATION

---



#### WARNING

Pay very careful attention when working in hazardous environments. There is a risk of explosion and the possibility of dangerous gases leaking. Always check whether the pipeline contains flammable, high pressure or high temperature materials before starting to work.



#### CAUTION

- Properly connect the inlet of the condensate discharged from the steam trap, the inlet of the condensate from the collection pipe, and the outlet of the mixed condensate without confusing them. (See the piping example)
- The DMX-N type inline mixer mixes condensates based on their pressure differential. Ensure that the minimum operating pressure differential ( $P1 - P2$ ) exceeds 0.05 MPa during use.

#### <Piping example>

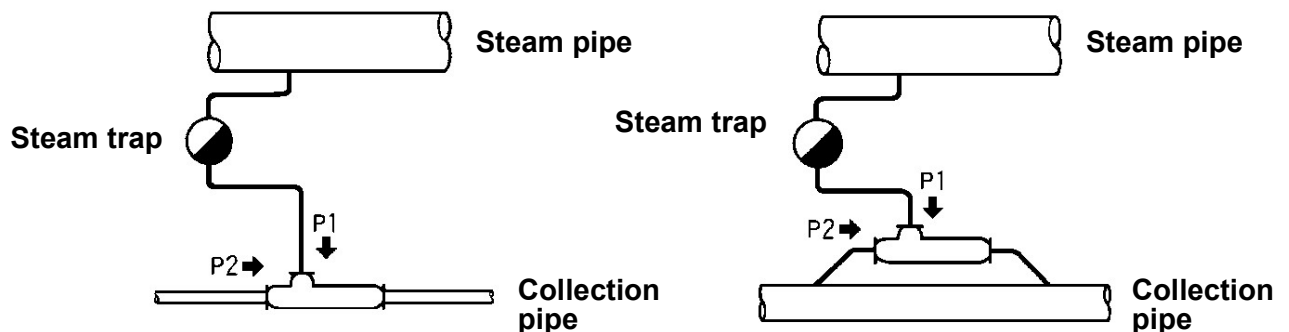

## **4 WARRANTY**

---

### **4.1 Warranty period**

The warranty period is 18 months after shipment or 12 months after installation, whichever occurs first.

### **4.2 Details of the warranty**

If the product stops working correctly within the warranty period, we will repair or replace the product free of charge if the cause of the trouble is not one of the following items.

- 1) The precautions described in this manual were not observed.
- 2) User's errors or mistakes such as an inappropriate installation or incorrect handling, or an excessively large impact caused by dropping
- 3) Problems caused by devices or equipment other than ours, or a disallowed use environment
- 4) When a repair or modification has been performed by anyone other than us or people who are authorized to make such repairs
- 5) Intrusion of salt or other substances that promote significant rust or corrosion or problems from fluids that contain the same substances
- 6) Attachment or accumulation of foreign matter in the pipe, such as dust and scale
- 7) Problems from fires, natural disasters, or other force majeure which is not our responsibility

### **4.3 Warranty limitation**

The remedy available under the warranty shall not exceed the sales price of the products delivered, for any cause whatsoever.

## 5 SERIAL NUMBER (S. No.) DESIGNATION

The following 4-digit or 9-digit “S.No.” is displayed on the product.

- For 4-digit display

S.No. □□□□

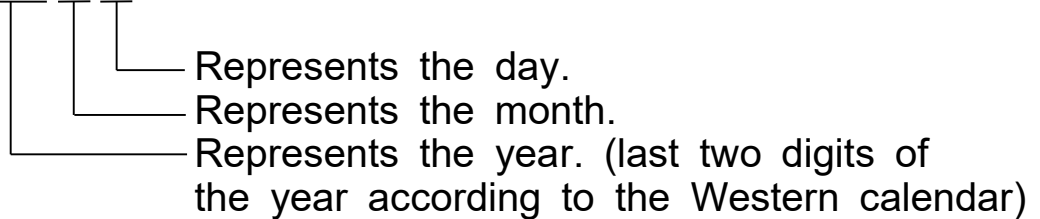

Example of serial number designation

1 7 1 1 → Jan.1, 2017

2 9 X M → Oct. 21, 2029

- For 9-digit display

S.No. □□□□□□□□□

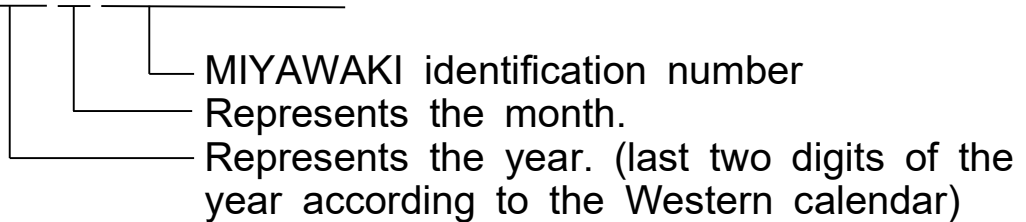

Example of serial number designation

1 7 1 1 2 C 0 2 0 → Jan., 2017

2 9 X 0 5 M 0 5 0 → Oct., 2029

### Month designation system

Month	1	2	3	4	5	6	7	8	9	10	11	12
Symbol	1	2	3	4	5	6	7	8	9	X	Y	Z

### Day designation system

Day	1	2	3	4	5	6	7	8	9	10	11	12
Symbol	D	E	F	G	H	J	K	L	M	N	O	P

Day	13	14	15	16	17	18	19	20	21	22	23	24
Symbol	D	E	F	G	H	J	K	L	M	N	O	P

Day	25	26	27	28	29	30	31
Symbol	Q	R	S	T	U	V	W

## 6 GUIDANCE FOR READING SPECIAL PRODUCT NAME

---

○○○-○○-□

**Special symbol:**  
**Symbol apply only to special product**  
**(Please refer to table 1 for details)**  
 English letter after “-“

**Model symbol:**  
**Product model number**

Table 1 Symbol description

Suffix	Special contents
A	Trap for high-pressure gas installed property (only for Gas Trap)
C	Blow valve attached
K	Change of gasket
L	Special face to face dimension
M	Change of parts material
P, T	Change of operating pressure, temperature, condensate capacity, etc
R	Change of screen mesh
V	Change of air vent
X	Other than mentioned above or complex of special contents above



---

For any questions about the product that you purchased or about the details in this user's manual, please contact the following.

- © 2023 MIYAWAKI INC.

This user's manual may not be reproduced or copied in whole or in part, without the written consent of MIYAWAKI INC.

- Some special specifications of the product you have, may found to be different from the ones in the user's manual. If you have any question, please contact MIYAWAKI, our local authorized agent, or the company where you purchased the product.
-



If you need any assistance regarding this manual, please contact MIYAWAKI INC.'s International Sales Dept. or its local representative. By scanning QR Code, you can access inquiry form.



**INTERNATIONAL SALES DEPT.**

2-1-30, Tagawakita, Yodogawa-ku, Osaka, 532-0021, Japan

Tel: +81-6-6302-5549

[www.miyawaki-inc.com/en](http://www.miyawaki-inc.com/en) e-mail: [export@miyawaki-inc.co.jp](mailto:export@miyawaki-inc.co.jp)

EU Importer and Authorized representative:



Birnbaumsmühle 65, 15234 Frankfurt (Oder), Germany

Tel: +49-335-4007-0097

[www.miyawaki.de](http://www.miyawaki.de) e-mail: [info@miyawaki.de](mailto:info@miyawaki.de)

China Importer and Authorized representative:



Room902, Building 8, Huaqing Chuangzhi Park, No.3 Qingyan Road, Huishan District, Wuxi City Jiangsu Province China

Tel: +86-510-8359-5125

[www.miyawaki-inc.com.cn](http://www.miyawaki-inc.com.cn) e-mail: [mywkwest@miyawaki-inc.com.cn](mailto:mywkwest@miyawaki-inc.com.cn)

808123-02 2310

**DMX-N**