

TEMPERATURE CONTROL STEAM TRAP

TBU4

USER'S MANUAL



 **MIYAWAKI INC.**

SAFETY GUIDE

The model TBU4 is a bimetal temperature control steam trap that has superior durability and essentially doesn't allow steam to leak.

In order to get maximum benefit from this product, be sure to read this manual before installing it.

The following warnings and cautions are shown at appropriate places in this manual.



Failure to observe this type of precaution may lead to serious injury or death.



Failure to follow this type of precaution can lead to injury or damage to equipment and property.

Table of Contents

| | | |
|----|---|----|
| 1 | SPECIFICATIONS AND MARKINGS | 1 |
| 2 | CONSTRUCTION DETAILS | 2 |
| 3 | INSTALLATION | 3 |
| 4 | SETTING THE TEMPERATURE | 4 |
| 5 | STROKE CHART | 5 |
| 6 | OPERATION | 6 |
| 7 | MAINTENANCE | 7 |
| 8 | SCALE REMOVAL OPERATION (TYPE TB-SR ONLY) | 10 |
| 9 | TROUBLESHOOTING | 12 |
| 10 | WARRANTY | 13 |
| 11 | SERIAL NUMBER (S. No.) DESIGNATION | 14 |
| 12 | GUIDANCE FOR READING SPECIAL PRODUCT NAME | 15 |

1 SPECIFICATIONS AND MARKINGS



WARNING

Be sure not to use this product at higher pressures than the specified maximum allowable pressure (PMA) or at temperatures higher than the specified maximum allowable temperature (TMA).

The following items are displayed on the name label or the side of the product. Check each item to avoid misuse of the product.

- 1) Maximum allowable pressure (PMA): 4.0 MPa (580 psig)
*TBU4B-6C: 0.98 MPa (142 psig)
 - 2) Maximum allowable temperature (TMA): 400 °C (752 °F)
*TBU4B-6C: 183 °C (361 °F)
*TBU4-6-SR: 230 °C (446 °F)
 - 3) Maximum Operating pressure (PMO): 0.6 MPa (87 psig)
 - 4) Maximum operating temperature (TMO): 220 °C (428 °F)
*TBU4B-6C: 183 °C (361 °F)
 - 5) Size: 8 mm (1/4"), 10 mm (3/8")
 - 6) Set temperature: The temperature at which the condensate will be discharged from the steam trap.
 - 7) Year of production: The two leftmost digits in the four-digit or nine-digit 'S. No.' are the last two digits of the year of production.
 - 8) Flow direction: Shown by an arrow
 - 9) Body material: SUS F304
 - 10) Model symbol: Showing the product model name
- Some pictures and illustrations in this manual are examples of TBU4 models. For more details regarding dimensions and other specifications, please refer to the catalog.

The model TBU4 fully complies with the requirements of the European Pressure Equipment Directive 2014/68/EU. It is classified according to Article 4, Section 3 of the PED, which does not allow to bear the CE marking.

2 CONSTRUCTION DETAILS

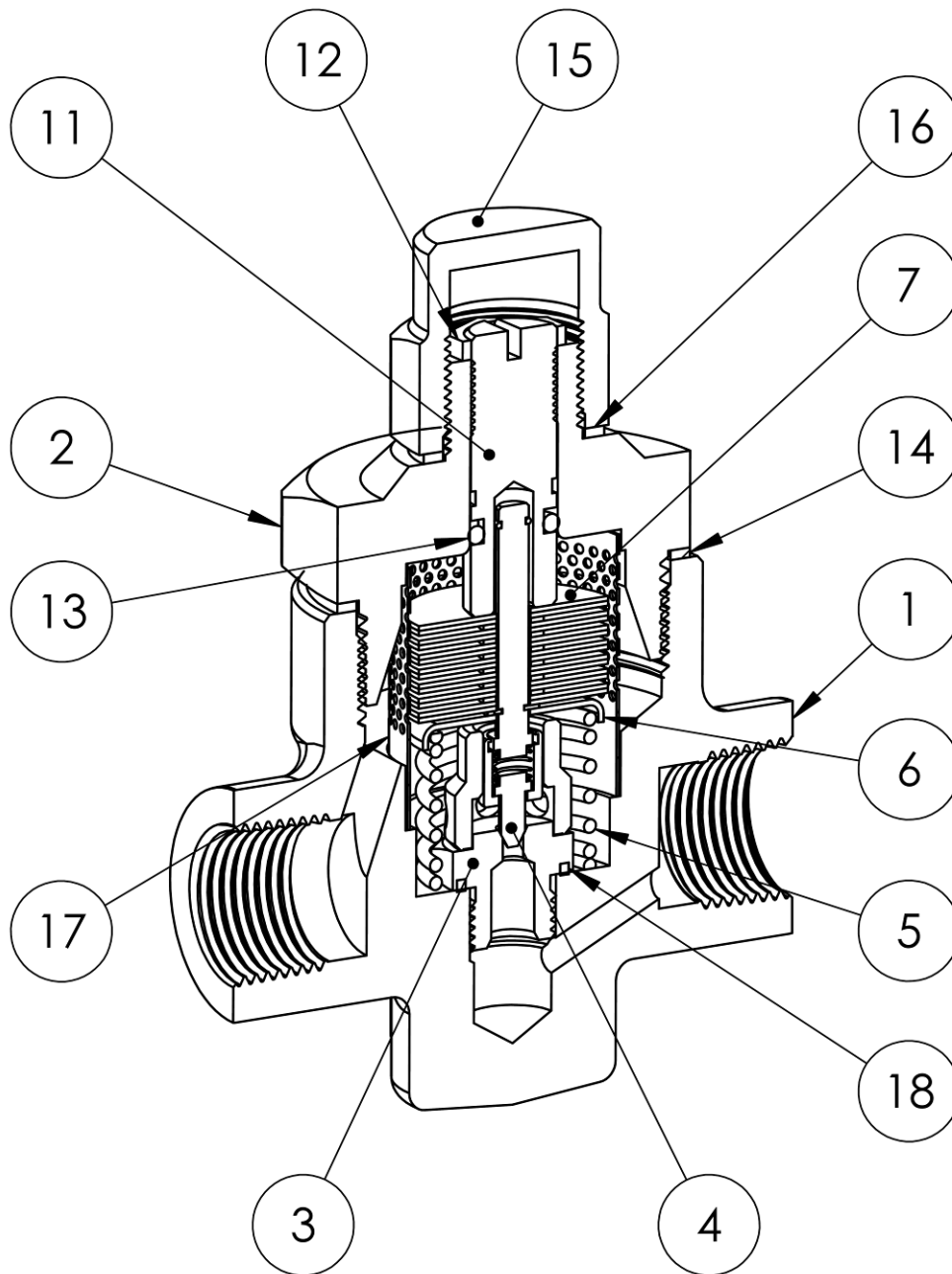

-
- | | | |
|---------------|-----------------|------------------|
| 1. Body | 6. Spring Plate | 14. Cover Gasket |
| 2. Cover | 7. Bimetal | 15. Cap |
| 3. Valve Seat | 11. Adjust Bolt | 16. Cap Gasket |
| 4. Valve | 12. Adjust Nut | 17. Screen |
| 5. Spring | 13. O-Ring | 18. Seat Gasket |

3 INSTALLATION



WARNING

Pay very careful attention when working in hazardous environments. There is a risk of explosion and the possibility of dangerous gases leaking. Always check whether the pipeline contains flammable, high pressure or high temperature materials before starting to work.

- Make sure that isolation valves are installed on both the upstream and downstream lines.



CAUTION

Before installing the product, open both isolation valves and the bypass valve, if one exists, to blow out any debris or dirt inside the pipeline. After blowing out the line, before starting to work, close the isolation valves and allow time for the temperature to drop to a safe working temperature.

When installing the product, be sure to leave clearance for maintaining it.

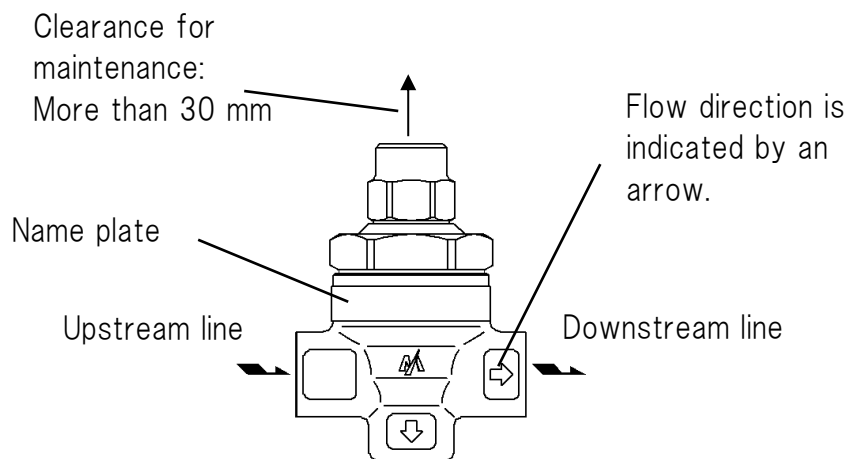

- (1) Remove the dustproof seals covering both connections.
※Products shipped in plastic bags may not have dustproof seals.
- (2) Check the flow direction indicated on the side of the body.
- (3) The TBU4 can be used for both horizontal and vertical lines. However, be sure not to install it upside-down in a horizontal line, as it will cause the trap to malfunction. When installing a TBU4 in a horizontal line, be sure to maintain a slight slope to the line, so that any condensate will flow smoothly.
- (4) Open the isolation valve on the upstream line and make sure the product works normally.

4 SETTING THE TEMPERATURE

WARNING

Only set the temperature when the body temperature reached room temperature, before any steam is flowing. Be sure not to set the temperature while the steam is in operation.

4.1 Set temperature

The set temperature is the temperature at which condensate will be discharged from the temperature control steam trap. It is set to the temperature specified by the customer when shipped. If the customer doesn't specify a temperature, it is always set to 70 °C at a pressure of 0.5 MPa, as the factory default setting.

4.2 Setting the temperature

- 1) Remove the cap (15).
- 2) Hold the adjust bolt (11) using a screwdriver, and loosen the adjust nut (12) using a wrench.
- 3) Screw the adjust bolt (11) slowly clockwise until it stops. This position is the starting point to set the temperature.
*Note not to tighten the adjust bolt (11) too tightly.
- 4) See the stroke chart in Section 5 to find the number of turns corresponding to the temperature you want.
- 5) Screw the adjust bolt (11) counterclockwise the number of turns specified in the stroke chart.
- 6) Hold the adjust bolt (11) using a screwdriver, and then lightly tighten the adjust nut (12).
- 7) Attach the cap (15).

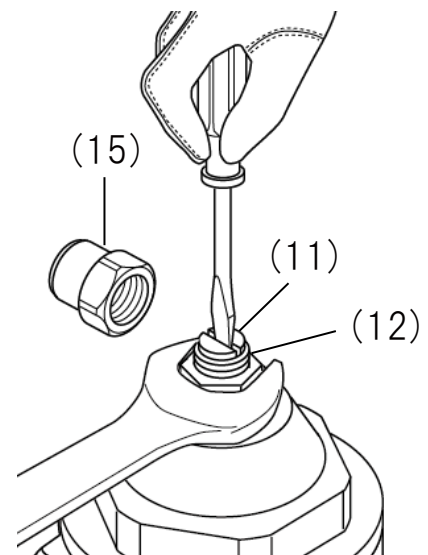

4.3 Precautions for setting the temperature

Steam trace

Basically, the set temperature should be the temperature used to control the objects being heated.

Other equipment

Basically, use the factory default setting. (70 °C at 0.5 MPa).

※Please consult us for the proper set temperature.

5 STROKE CHART

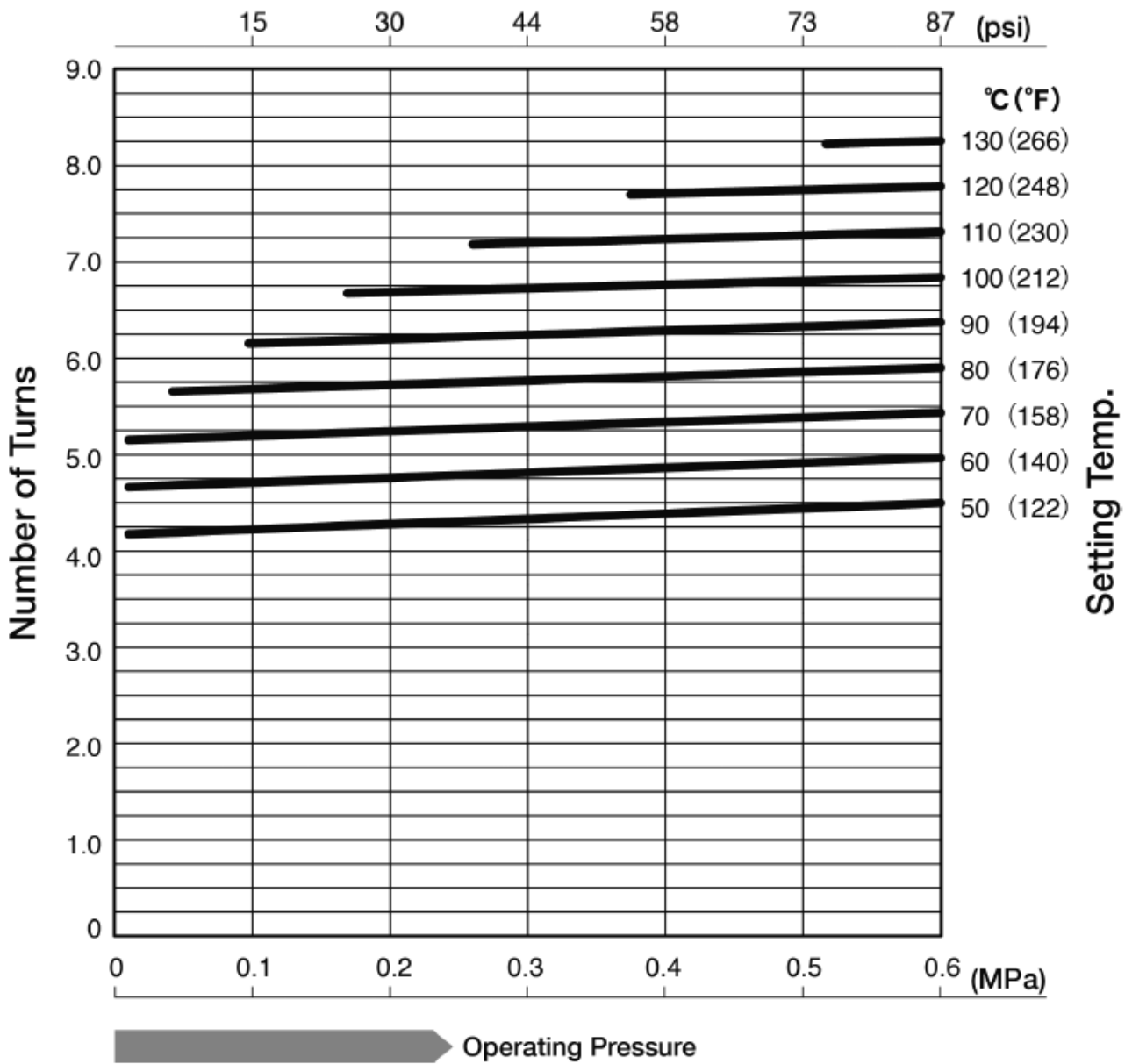

6 OPERATION



CAUTION

Before starting operation, open the bypass valve or blow valve completely and blow off the scale in the piping.

6.1 Operation procedure

- 1) After blowing off the scale from the piping, close the bypass valve or blow valve.
- 2) Open the stop valve on the trap outlet side.
- 3) Open the stop valve on the trap inlet side.

6.2 Stop procedure

- 1) Close the stop valve on the trap inlet side.
- 2) Close the stop valve on the trap outlet side.

* When stopping for a long time, completely drain the condensate from the piping and trap and close the valves before and after the trap.

7 MAINTENANCE



WARNING

- Before removing the trap from the pipe or disassembling it, be sure to close the isolation valves. Then, release the residual pressure from the trap body (make sure that the pressure in the main body is equal to the atmospheric pressure). After it has fully cooled down (after the temperature of the main body has reached ambient temperature), confirm for safe conditions and then begin work.
- Even when the isolation valves are closed, there may be residual internal pressure due to leaks from the isolation valves. Therefore, be very careful.



CAUTION

- When replacing parts, make sure the replacement parts are supplied by **MIYAWAKI**.

The performance of steam traps deteriorates gradually over time due to wear, corrosion or dirt accumulating around the valve and the valve seat. Please conduct periodic diagnosis of traps in order to keep steam control systems and equipment working well.

7.1 Tools for Diagnosis Steam Traps

■ Dr. Trap

Dr. Trap is a sophisticated steam trap management system for diagnosing steam traps automatically by measuring the vibration and temperature of the steam trap. Survey results are stored in the testing equipment and transferred to a steam trap analysis software. The software aggregates and analyses steam trap survey data, identifying faulty steam traps, providing steam loss and financial loss data, estimating CO₂ emissions corresponding to leaking steam traps and providing many other analyze possibilities to manage the steam trap population easily.

■ Dr. Trap Jr.

Dr. Trap Jr. is an inexpensive and easily to handle steam trap diagnostic system consisting of an ultrasonic checker, temperature probe and a sophisticated analysis software. The software allows to determine the condition of a steam trap, to estimate steam and financial losses and the related CO₂ emissions.

For more details, please, check our homepage:

<https://www.miyawaki.net/en/products/steam-trap-management-system>

or ask our local representative.

7.2 Repairs

When a trap fails, it is necessary to clean the internal parts and to replace damaged parts. Take the failed trap apart following the steps below.

7.2.1 Disassembling the trap

- 1) Loosen the cover (2). Remove the adjustment unit including the cap (15), the adjust bolt (11), the adjust nut (12), the O-ring (13) and the cap gasket (16).
- 2) Remove the bimetal unit and the spring (5) by hand.
- 3) Remove the valve seat (3) using a socket wrench.

After cleaning the trap and replacing damaged parts, reassemble the parts in reverse order as follows.

7.2.2 Reassembling the trap

- 1) Insert the seat gasket (18), screw the valve seat (3) into the body (1).
- 2) Reinstall the screen (17) in the body (1).
- 3) Reinstall the spring (5) on the valve seat (3).
- 4) Reinstall the bimetal unit so that the spring plate (6) of the bimetal unit fits on the spring (5).
- 5) After placing the cover gasket (14) on the body (1), screw the cover (2) with the adjustment unit onto the body (1).



CAUTION

- **When reassembling the trap, make sure to replace the O-ring (13), the cover gasket (14), the cap gasket (16), the seat gasket (18), with a new one.**

Torque table

| Parts | Tools | Across the flats | Torque |
|-----------------|---------------|------------------|---------|
| Cover (2) | Torque wrench | 41 mm (1.61") | 150 N·m |
| Valve Seat (3) | Torque wrench | 14 mm (0.55") | 12 N·m |
| Cap (15) | Torque wrench | 22 mm (0.87") | 45 N·m |
| Adjust Nut (12) | Wrench | 12 mm (0.47") | — |

* When the adjustment unit is disassembled, after reassembling it set the temperature again, following the steps shown in Section 4, "Setting the temperature".

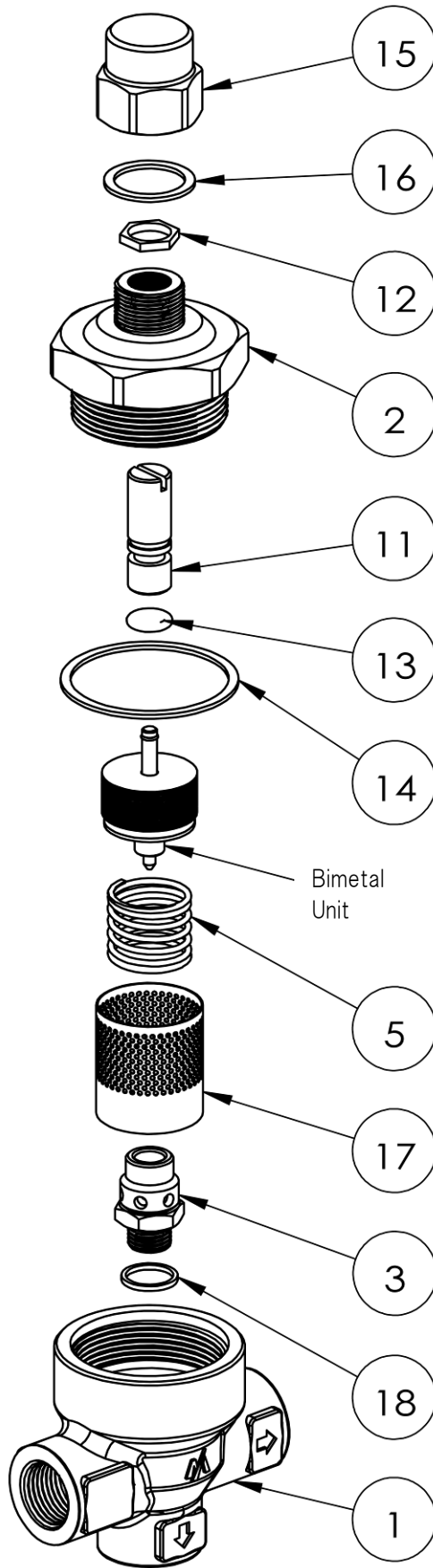

- 1. Body
- 2. Cover
- 3. Valve Seat
- 4. Bimetal Unit (Valve)
- 5. Spring
- 6. Spring Plate
- 7. Bimetal
- 8. Washer
- 9. E-Ring
- 10. Shaft Ring
- 11. Adjust Bolt
- 12. Adjust Nut
- 13. O-Ring
- 14. Cover Gasket
- 15. Cap
- 16. Cap Gasket
- 17. Screen
- 18. Seat Gasket

8 SCALE REMOVAL OPERATION (TYPE TB-SR ONLY*)

*Note: The drawings in this section use the Type TB7N/TB9N-SR as representative examples. The scale removal operation and maintenance can be performed as described in this section for the Type TBU4-SR as well.



WARNING

- Never loosen the gland nut (32). It is dangerous as steam or condensate will leak out from the spindle (31).



CAUTION

- Wear protective equipment, such as protective glasses and work gloves, when performing the work.
- Exercise caution when you perform the work as high temperature condensate or steam will leak out from the outlet of the unit when using the handle (37).
- Although the gland packings (33 and 34) are properly tightened at the time of shipment, a leak may occur from the gland nut (32) due to stress relaxation. In that case, retighten the gland nut.

8.1 Necessity of removing scale

In temperature control traps, foreign matter (scale) in the pipeline adhere to and deposit into the valve section (especially around the valve port) after long use, causing a reduction in the discharge flow rate, clogging, and other abnormalities, which make normal operation impossible.

Type TB-SR has a function that allow you to restore normal operation by ejecting scale that has adhered to and been deposited on the valve port to the outside of the unit, using the handle (37) in the lower section from the outside*. To maintain the performance of steam equipment and devices, perform the following scale removal operation periodically to restore normal operation.

*Note: When a malfunction is caused by other factors, normal operation may not be restored by this operation.

In such cases, please contact MIYAWAKI, our local authorized agent, or the place where you purchased.

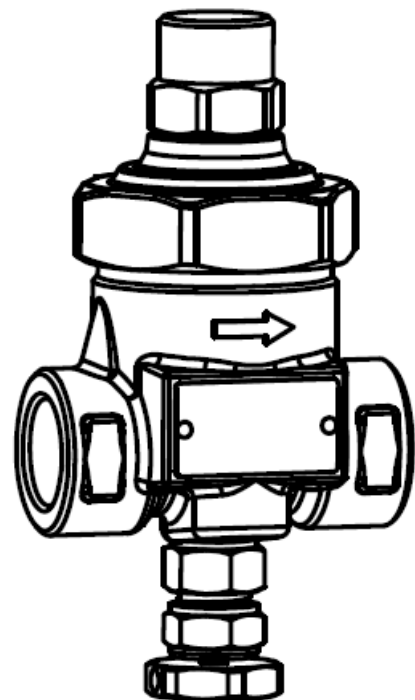

8.2 Scale removal operation procedure

- 1) Wear appropriate protective equipment before you start the work.
- 2) Turn the handle (37) counterclockwise (↺) when looking from the top of the unit.

Be careful as high temperature condensate or steam will suddenly leak-out from the outlet of the unit.

- 3) While paying attention to the outlet of the unit, turn the handle (37) clockwise (↻) two to three turns.
- 4) Repeat Steps 2) and 3) two to three times to blow off the scale that has adhered to the valve port.
- 5) Turn the handle (37) clockwise lightly (↻) until it stops. (Pull the spindle (31) all the way down.)
- 6) Check the surface temperature about one hour after the above operation. If the indicated temperature is around the set temperature, the normal operation of the unit has been restored.
- 7) If you have any questions, please contact MIYAWAKI, our local authorized agent, or the place where you purchased.

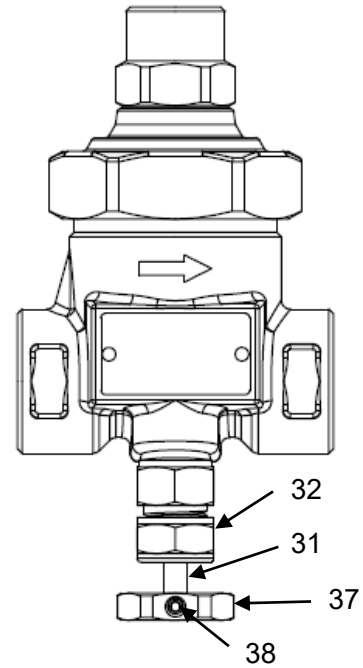

| Part No. | Part name |
|----------|----------------------|
| 31 | Spindle |
| 32 | Gland nut |
| 37 | Handle |
| 38 | Hexagon socket screw |

8.3 Maintenance

➤ Further tightening the gland nut

When a leak occurs from the gland nut (32), retighten the gland nut slightly.

➤ Replacing the scale removal unit

If the scale removal device malfunctions, it needs to be replaced on a unit basis. (Replacement on a sub-part basis is not possible.)

➤ Torque table

| Part | Tool | Width across flats | Torque |
|----------------|---------------|--------------------|--------|
| Gland Nut (32) | Torque wrench | 17 mm (0.67") | 20 N·m |
| Removal Unit | Torque wrench | 17 mm (0.67") | 25 N·m |

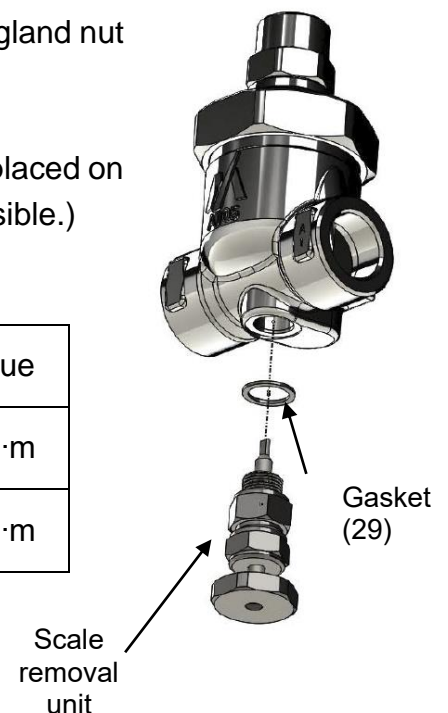

9 TROUBLESHOOTING

| Problem | | Possible cause | Solution |
|---|---|--|--|
| Steam leaks or blows through. | | Dirt is stuck around the valve (4) or valve seat (3) | Clean the valve (4) and the valve seat (3). |
| | | The valve seat (3) is loose. | Tighten the valve seat (3). *1 |
| | | Damage, erosion or corrosion of the valve (4) or valve seat (3). | Replace the valve (4) and the valve seat (3) as a set. |
| | | The seat gasket (18) is damaged. | Replace the seat gasket (18). |
| | | The bimetal (7) is damaged. | Replace the bimetal unit. |
| | | The adjust bolt (11) is backed out too far. | Set the temperature again. |
| | | Wrong installation direction | Reinstall the product in the correct direction. |
| Steam leaks from the body. | From the connection between the body and cover or between the body and cap | The cover (2) is loose. | Tighten the cover (2). *2 |
| | | The cover gasket (14) is damaged. | Replace the cover gasket (14). |
| | | The O-ring (13) is damaged. | Replace the O-ring (13). |
| Insufficient condensate discharged, or no condensate discharged. | | The screen (17) is clogged. | Clean the screen (17). *3 |
| | | Dirt has built up on or around the valve seat (3). | Clean the valve seat (3). |
| | | Dirt accumulated in the fluid passage of the body (1) | Clean the body (1). |
| | | The bimetal (7) is damaged. | Replace the bimetal unit. |
| | | The adjust bolt (11) is too tight. | Set the temperature again. |
| | | Insufficient condensate capacity. | Replace the trap with a larger capacity trap. |

*1 and *2: Refer to the torque table in Section 7, "Maintenance" to retighten the parts with the correct torque.

*3: When the screen (17) is clogged, TBU4B-C can blow the dirt away from the outer section of the screen.

10 WARRANTY

10.1 Warranty period

The warranty period is 18 months after shipment or 12 months after installation, whichever occurs first.

10.2 Details of the warranty

If the product stops working correctly within the warranty period, we will repair or replace the product free of charge if the cause of the trouble is not one of the following items.

- 1) The precautions described in this manual were not observed.
- 2) User's errors or mistakes such as an inappropriate installation or incorrect handling, or an excessively large impact caused by dropping
- 3) Problems caused by devices or equipment other than ours, or a disallowed use environment
- 4) When a repair or modification has been performed by anyone other than us or people who are authorized to make such repairs
- 5) Intrusion of salt or other substances that promote significant rust or corrosion or problems from fluids that contain the same substances
- 6) Consumable parts such as Packing, Gasket, O-ring, Diaphragm, etc.
- 7) Attachment or accumulation of foreign matter in the pipe, such as dust and scale
- 8) Problems from fires, natural disasters, or other force majeure which is not our responsibility

10.3 Warranty limitation

The remedy available under the warranty shall not exceed the sales price of the products delivered, for any cause whatsoever.

11 SERIAL NUMBER (S. No.) DESIGNATION

The following 4-digit or 9-digit 'S. No.' is displayed on the product.

- For 4-digit display

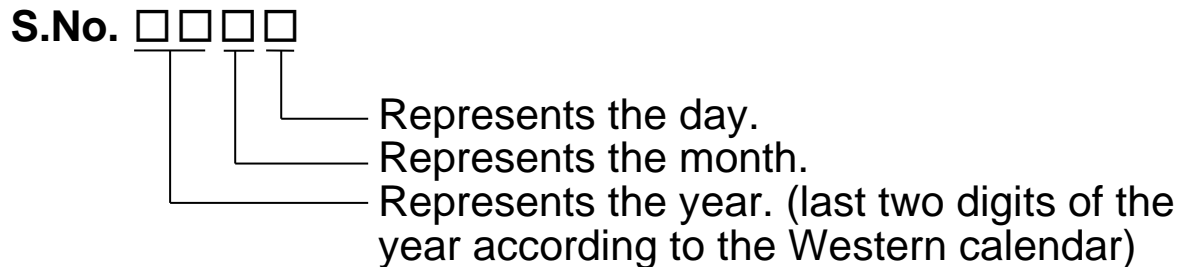

Example of serial number designation
 1 7 1 1 → Jan.1, 2017
 2 9 X M → Oct. 21, 2029

- For 9-digit display

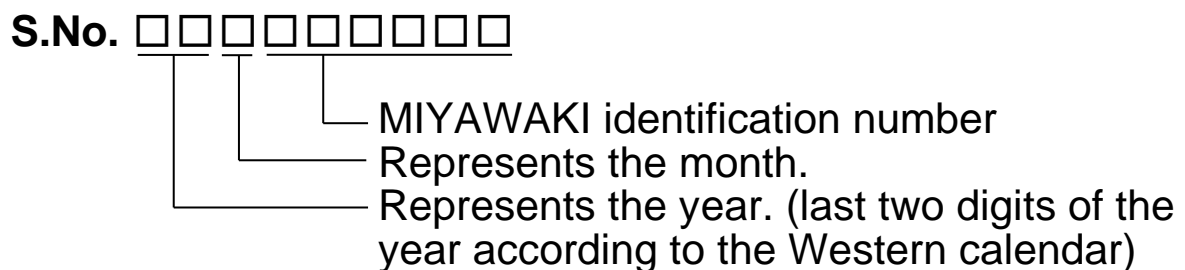

Example of serial number designation
 1 7 1 1 2 C 0 2 0 → Jan., 2017
 2 9 X 0 5 M 0 5 0 → Oct., 2029

Month designation system

| | | | | | | | | | | | | |
|--------|---|---|---|---|---|---|---|---|---|----|----|----|
| Month | 1 | 2 | 3 | 4 | 5 | 6 | 7 | 8 | 9 | 10 | 11 | 12 |
| Symbol | 1 | 2 | 3 | 4 | 5 | 6 | 7 | 8 | 9 | X | Y | Z |

Day designation system

| | | | | | | | | | | | | |
|--------|---|---|---|---|---|---|---|---|---|----|----|----|
| Day | 1 | 2 | 3 | 4 | 5 | 6 | 7 | 8 | 9 | 10 | 11 | 12 |
| Symbol | 1 | 2 | 3 | 4 | 5 | 6 | 7 | 8 | 9 | A | B | C |

| | | | | | | | | | | | | |
|--------|----|----|----|----|----|----|----|----|----|----|----|----|
| Day | 13 | 14 | 15 | 16 | 17 | 18 | 19 | 20 | 21 | 22 | 23 | 24 |
| Symbol | D | E | F | G | H | J | K | L | M | N | O | P |

| | | | | | | | |
|--------|----|----|----|----|----|----|----|
| Day | 25 | 26 | 27 | 28 | 29 | 30 | 31 |
| Symbol | Q | R | S | T | U | V | W |

12 GUIDANCE FOR READING SPECIAL PRODUCT NAME

○○○-○○-□

Special symbol:
 The symbol applies only to special products.
 (Please refer to table 1 for details)

Model symbol:
 Product model number

Table 1 Symbol description

| Suffix | Special contents |
|--------|--|
| A | Trap for high-pressure gas installed property (only for Gas Trap) |
| C | Blow valve attached |
| K | Change of gasket |
| L | Special face to face dimension |
| M | Change of parts material |
| P, T | Change of operating pressure, temperature, condensate capacity, etc. |
| R | Change of screen mesh |
| V | Change of air vent |
| X | Other than mentioned above or complex of special contents above |

-
- For any questions about the product that you purchased or about the details in this user's manual, please contact the following.
 - © 2018 MIYAWAKI INC
This user's manual may not be reproduced or copied in whole or in part, without the written consent of MIYAWAKI INC.
 - Some special specifications of the product may found to be different from the ones in the user's manual. If you have any question, please contact MIYAWAKI, our local authorized agent, or the company where you purchased the product.
 - In the interest of the development and improvement of our products, MIYAWAKI Inc. reserves the right to change the specification of the products without prior notice.
-



If you need any assistance regarding this manual, please contact MIYAWAKI INC.'s International Sales Dept. or its local representative. By scanning QR Code, you can access inquiry form.



INTERNATIONAL SALES DEPT.
2-1-30, Tagawakita, Yodogawa-ku, Osaka, 532-0021, Japan
Tel: +81-6-6302-5549
www.miyawaki-inc.com/en e-mail: export@miyawaki-inc.co.jp

EU Importer and Authorized representative:



Birnbaumsmühle 65, 15234 Frankfurt (Oder), Germany
Tel: +49-335-4007-0097
www.miyawaki.de e-mail: info@miyawaki.de

China Importer and Authorized representative:



Room 902, Building 8, Huaqing Chuangzhi Park, No.3 Qingyan Road, Huishan District,
Wuxi City Jiangsu Province, China
Tel: +86-510-8359-5125
www.miyawaki-inc.com.cn e-mail: mywkwest@miyawaki-inc.com.cn

808125-04 2404

TBU4