

**LEVER FREE  
BALL FLOAT STEAM TRAP**

# **G30**

---

**USER'S MANUAL**



 **MIYAWAKI INC.**

# SAFETY GUIDE

The models G30 are ball float steam traps that have superior durability and are equipped with a membrane capsule (thermo element) type air vent.

In order to get maximum benefit from this product, be sure to read this manual before installing it.

The following warnings and cautions are shown at appropriate places in this manual.



Failure to observe this type of precaution may lead to serious injury or death.



Failure to follow this type of precaution can lead to injury or damage to equipment and property.

## Table of Contents

---

1	SPECIFICATIONS AND MARKINGS	1
2	CONSTRUCTION DETAILS	2
3	INSTALLATION	3
4	OPERATION	5
5	MAINTENANCE	6
6	TROUBLESHOOTING	11
7	WARRANTY	13
8	SERIAL NUMBER DESIGNATION	14
9	GUIDANCE FOR READING SERIAL PRODUCT NAME	15

# 1 SPECIFICATIONS AND MARKINGS

---



## WARNING

**Be sure not to use this product at higher pressures than the specified maximum allowable pressure (PMA) or at temperatures higher than the specified maximum allowable temperature (TMA).**

The following items are displayed on the name plate or the side of the product.

Check each item to avoid misuse of the product.

(1) Maximum allowable pressure (PMA): 2.5 MPa (363 psig)

(2) Maximum allowable temperature (TMA): 250 °C (482 °F)

(3) Maximum operating pressure (PMO):

G30-2(F): 0.2 MPa (29 psig)

G30-6(F): 0.6 MPa (87 psig)

G30-10(F): 1.0 MPa (145 psig)

G30-21(F): 2.1 MPa (305 psig)

(4) Maximum operating temperature (TMO): 235 °C (455 °F)

(5) Size:

G30(Rc, NPT): 20mm (3/4"), 25mm (1"), 32mm (1 1/4"), 40mm (1 1/2")

G30-F: 32mm (1 1/4"), 40mm (1 1/2")

(6) Year of production: The two leftmost digits in the four-digit or nine-digit 'S. No.' are the last two digits of the year of production.

(7) Flow direction: Shown by an arrow.

(8) Body material: Ductile cast iron FCD450

(9) Model symbol: Showing the product name

- Some pictures and illustrations in this manual are examples of G30 models. For more details regarding dimensions and other specifications, please refer to the catalog.

The models G30 fully comply with the requirements of the European Pressure Equipment Directive 2014/68/EU. They are classified according to Article 4, Section 3 of the PED, which does not allow to bear the CE marking.

## 2 CONSTRUCTION DETAILS

---

### G30 model

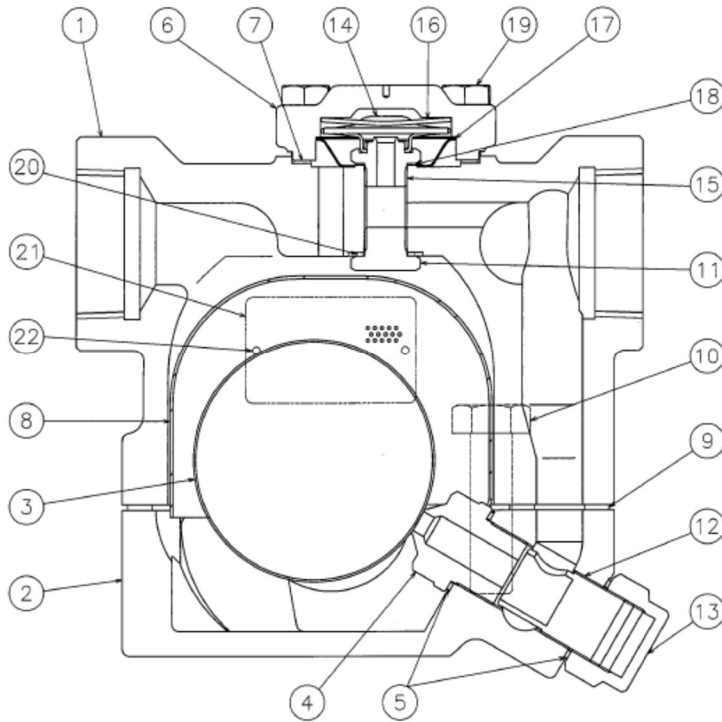

- (1) Body
- (2) Bottom Cover
- (3) Float
- (4) Valve Seat
- (5) Seat Gasket
- (6) Air Vent Cover
- (7) Air Vent Cover Gasket
- (8) Screen (20 mesh or equivalent)
- (9) Cover Gasket
- (10) Cover Bolt
- (11) Air Vent Plug
- (12) Protector
- (13) Cap
- (14) Membrane Capsule (Thermo Element)
- (15) Air Vent Seat
- (16) Stop Spring
- (17) Air Vent Screen
- (18) Air Vent Seat Gasket
- (19) Air Vent Cover Bolt
- (20) Plug Gasket
- (21) Name Plate
- (22) Rivet

### **3 INSTALLATION**

---



#### **WARNING**

**Pay very careful attention when working in hazardous environments. There is a risk of explosion and the possibility of dangerous gases leaking. Always check whether the pipeline contains flammable, high pressure or high temperature materials before starting to work**

- **Make sure that isolation valves are installed on both the upstream and downstream lines.**



#### **CAUTION**

- **Before installing the product, open both isolation valves to blow out any debris or dirt inside the pipeline.**
  - **After blowing out the line, before starting to work, close the isolation valves and allow time for the temperature to drop to a safe working temperature.**
  - **When installing the product, be sure to leave clearance for maintaining it.**
- (1) Remove the dustproof seals covering both connections.  
✂Products shipped in plastic bags may not have dustproof seals.
  - (2) Check the flow direction indicated on the side of the body.
  - (3) When installing the models G30 in a horizontal line, the air vent cover on the main body of the trap must be facing up. Also, be sure to maintain a slight slope to the line, so that any condensate will flow smoothly.
  - (4) Open the isolation valve on the upstream line and make sure the product works normally.

## G30 model

---

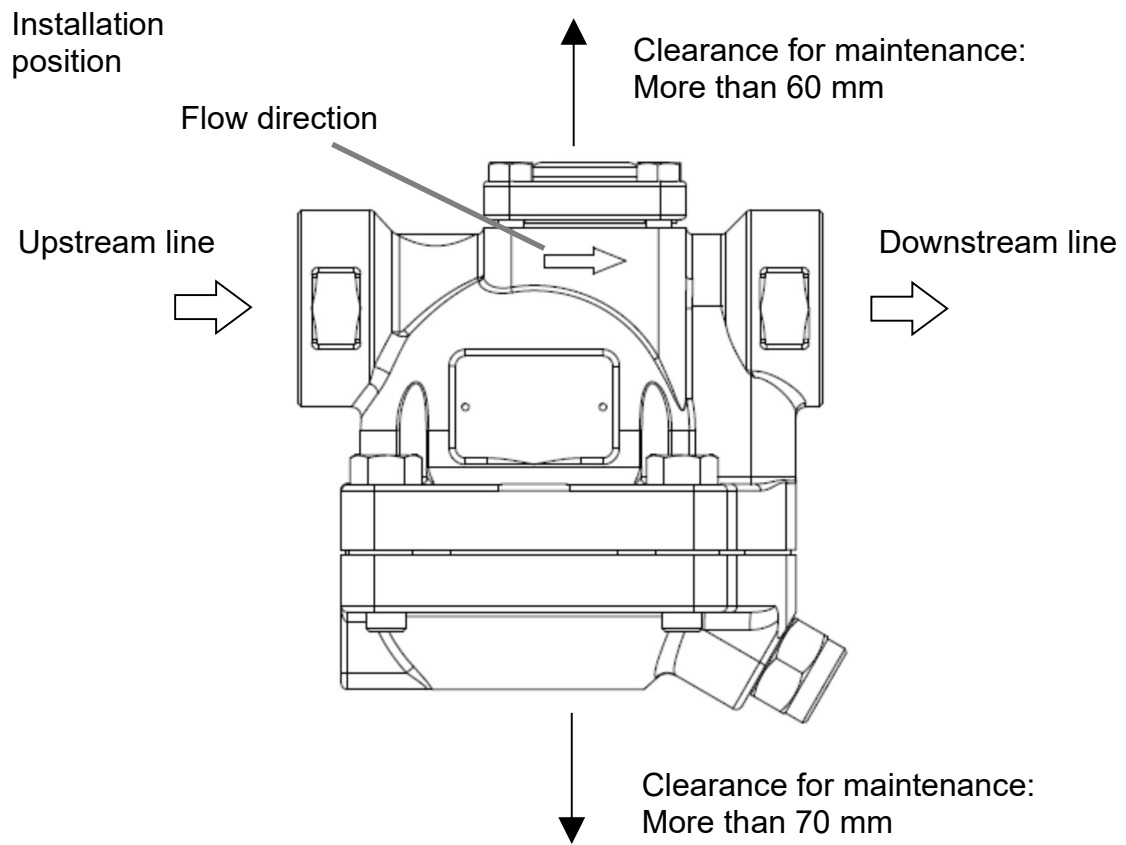

## **4 OPERATION**

---



### **CAUTION**

**Before starting operation, open the bypass valve or blow valve completely and blow off the scale in the piping.**

#### **4.1 Operation procedure**

- 1) After blowing off the scale from the piping, close the bypass valve or blow valve.
- 2) Open the stop valve on the trap outlet side.
- 3) Open the stop valve on the trap inlet side.

#### **4.2 Stop procedure**

- 1) Close the stop valve on the trap inlet side.
- 2) Close the stop valve on the trap outlet side.

\* When stopping for a long time, completely drain the condensate from the piping and trap and close the valves before and after the trap.

## 5 MAINTENANCE

---



### WARNING

- Before removing the trap from the pipe or disassembling it, be sure to close the isolation valves. Then, release the residual pressure from the trap body (make sure that the pressure in the main body is equal to the atmospheric pressure). After it has fully cooled down (after the temperature of the main body has reached ambient temperature), confirm for safe conditions and then begin to work.
- Even when the isolation valves are closed, there may be residual internal pressure due to leaks from the isolation valves. Therefore, be very careful.



### CAUTION

- When replacing parts, make sure the replacement parts are supplied by MIYAWAKI.

The performance of steam traps deteriorates gradually over time due to wear, corrosion or dirt accumulating around the valve and the valve seat. Please conduct periodic diagnosis of traps in order to keep steam control systems and equipment working well.

### 5.1 Tools for Diagnosing Steam Traps

#### ■ Dr. Trap

Dr. Trap is a sophisticated steam trap management system for diagnosing steam traps automatically by measuring the vibration and temperature of the steam trap. Survey results are stored in the testing equipment and transferred to a steam trap analysis software. The software aggregates and analyses steam trap survey data, identifying faulty steam traps, providing steam loss and financial loss data, estimating CO<sub>2</sub> emissions corresponding to leaking steam traps and providing many other analyze possibilities to manage the steam trap population easily.

#### ■ Dr. Trap Jr.

Dr. Trap Jr. is an inexpensive and easily to handle steam trap diagnostic system consisting of an ultrasonic checker, temperature probe and a sophisticated analysis software. The software allows to determine the condition of a steam trap, to estimate steam and financial losses and the related CO<sub>2</sub> emissions.

For more details, please, check our homepage:

<https://www.miyawaki.net/en/products/steam-trap-management-system>

or ask our local representative.



## 5.2 Repairs

When a trap fails, it is necessary to clean the internal parts and to replace damaged parts. Take the failed trap apart following the steps below.

### 5.2.1 Disassembling the trap

- 1) Loosen the 4 cover bolts (10) and remove the bottom cover (2).
- 2) Remove the screen (8), float (3), the valve seat (4) and the seat gasket (5), in that order.

Do not remove the cap (13) from the bottom cover (2).

### 5.2.2 Disassembling the air vent

- 1) Loosen the 4 air vent cover bolts (19) and remove the air vent cover (6) from the body (1).
- 2) Remove the membrane capsule (thermo element) (14), loosen and remove the air vent seat (15).
- 3) Remove the air vent seat gasket (18) and air vent screen (17) from the body (1).

Do not remove the air vent plug (11) from the body (1).



### CAUTION

**Clean the body (1) and bottom cover (2) with care not to damage the sealing surfaces. Scratches on the sealing surfaces may cause steam leakage.**

Take appropriate measures according to “6. Troubleshooting”. After cleaning the trap and replacing damaged parts, reassemble the parts in the opposite way as disassembling. Refer to the torque table for the necessary torque.

### 5.2.3 Reassembling the air vent

- 1) Put the air vent screen (17) back to the body (1).
- 2) Put the air vent seat gasket (18) to the body (1) and screw the air vent seat (15) into the body (1).

\* To prevent seizure, apply a small amount of anti-seize lubricant to the threads of the air vent seat (15).

- 3) Install the membrane capsule (thermo element) (14) in the groove of the air vent seat (15).

- 4) Install the stop spring (16) on the air vent cover (6).

\* Since the stop spring (16) is curved, fit it in the correct orientation as shown in the illustration. (The trap will not work properly if the stop spring (16) is installed in reverse.)

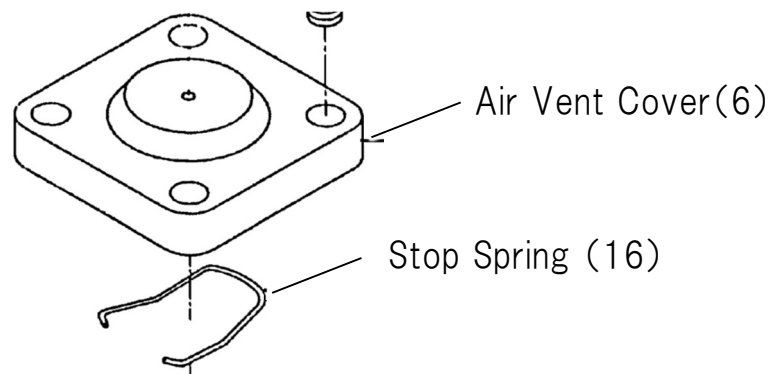

- 5) Put the air vent cover gasket (7) on the body (1), put the air vent cover (6) on the body (1) and tighten the air vent cover bolts (19).
  - \* To prevent seizure, apply a small amount of anti-seize lubricant to the threads of the air vent cover bolts (19).
 Tighten the air vent cover bolts (19) evenly crosswise.

#### 5.2.4 Reassembling the trap

- 1) Put the seat gasket (5) on the bottom cover (2).
  - \* To prevent seizure, apply a small amount of anti-seize lubricant to both sides of the seat gasket (5).
- 2) Screw the valve seat (4) into the bottom cover (2).
  - \* To prevent seizure, apply a small amount of anti-seize lubricant to the threads of the valve seat (4).
- 3) Put the cover gasket (9) and float (3) on the bottom cover (2).
- 4) Align the notch on the screen (8) with the valve seat (4) side as shown in the illustration, and fit it into inner circumference of the bottom cover (2) with the float (3).

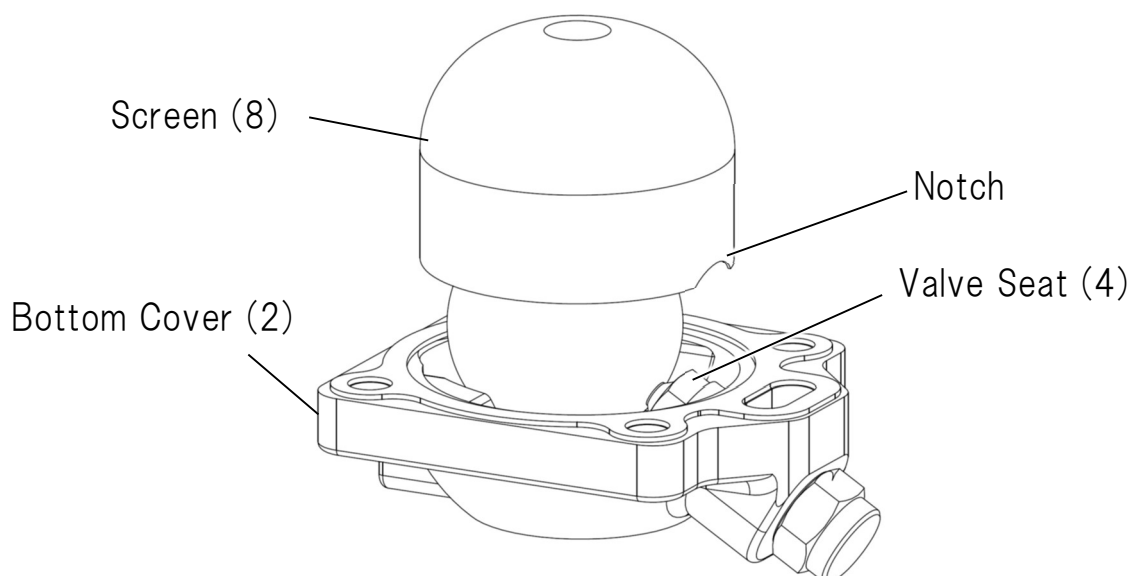

5) Install the bottom cover (2) with the screen (8) to the body (1).

When installing the bottom cover (2), make sure to install the body (1) and the bottom cover (2) in the same direction. Do not reverse the left and right sides. Tighten the cover bolts (10) which are inserted from the body side.

\* To prevent seizure, apply a small amount of anti-seize lubricant to the threads of the cover bolts (10).

Tighten the cover bolts (10) evenly crosswise.

\* Apply seal paste for expanded graphite to both sides of the cover gasket (9).

### Torque table

Parts	Tools	Across the flats	Torque
Valve Seat (4)	Torque wrench	22 mm (0.87")	65 N·m
Cover Bolt (10)	Torque wrench	19 mm (0.75")	80 N·m
Cap (13)	Torque wrench	27 mm (1.06")	65 N·m
Air Vent Plug (11)	Torque wrench	17 mm (0.67")	25 N·m
Air Vent Seat (15)	Torque wrench	17 mm (0.67")	25 N·m
Air Vent Cover Bolt (19)	Torque wrench	13 mm (0.51")	22 N·m



### CAUTION

When reassembling always replace the cover gasket (9), the seat gasket (5) of the valve seat (4), the air vent seat gasket (18) and the air vent cover gasket (7) with new ones.

Tighten the cover bolts (10) and air vent cover bolts (19) evenly crosswise.

## G30 model

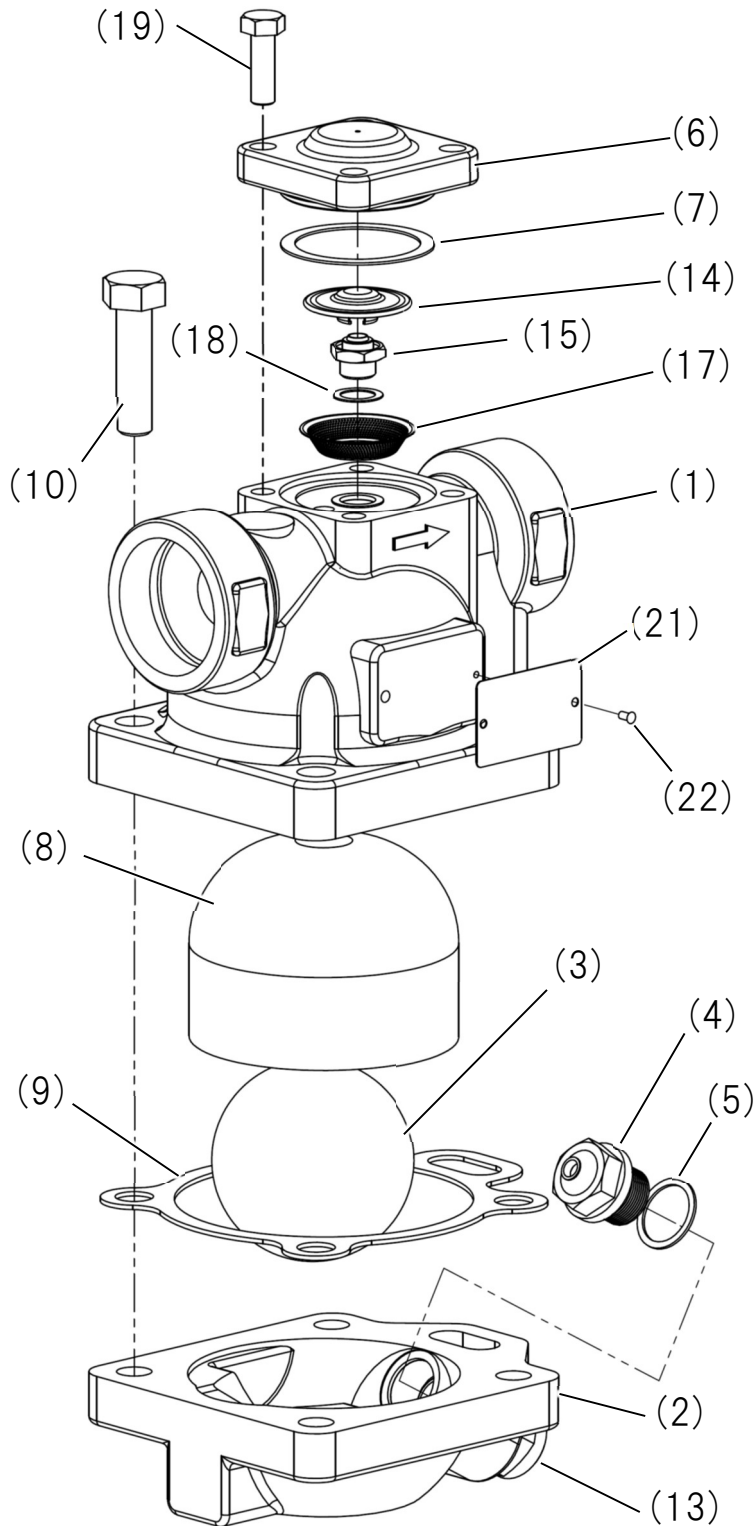

- (1) Body
- (2) Bottom Cover
- (3) Float
- (4) Valve Seat
- (5) Seat Gasket
- (6) Air Vent Cover
- (7) Air Vent Cover Gasket
- (8) Screen
- (9) Cover Gasket
- (10) Cover Bolt
- (13) Cap
- (14) Membrane Capsule  
(Thermo Element)
- (15) Air Vent Seat
- (17) Air Vent Screen
- (18) Air Vent Seat Gasket
- (19) Air Vent Cover Bolt
- (21) Name Plate
- (22) Rivet

## 6 TROUBLESHOOTING

Problem		Possible cause	Solution
<b>Steam leaks or blows through.</b>		Foreign material such as a scale or dirt is stuck to the float (3) or the valve seat (4).	Clean the float (3) or the valve seat (4).
		Foreign material such as a scale or dirt is stuck to the valve of membrane capsule (thermo element) (14) or the air vent seat (15).	Clean the valve of membrane capsule (thermo element) (14) or the air vent seat (15).
		Damage, wear or corrosion of the float (3) or valve seat (4).	Replace the float (3) or the valve seat (4).
		The valve seat (4) is loose.	Retighten the valve seat (4) *1
		The membrane capsule (thermo element) (14) is damaged.	Replace the membrane capsule (thermo element) (14).
		The air vent seat (15) is loose.	Retighten the air vent seat (15). *2
		Wrong installation position	Change the installation so that the air vent plug on the body of the trap is facing up.
		Wrong installation direction	Make sure the arrow on the main body matches the flow direction of the fluid.
<b>Steam leaks from the body</b>	From between the body and bottom cover	The cover bolts (10) are loose.	Retighten the cover bolts (10). *3
		Damage, wear or corrosion of the cover gasket (9).	Replace the cover gasket (9).
		The gasket sealing surface of the body (1) or bottom cover (2) is damaged.	Replace the body (1) or the bottom cover (2) with new ones.
	From between the body and air vent cover	The air vent cover bolts (19) are loose.	Retighten the air vent cover bolts (19). *4
		The air vent cover gasket (7) is damaged.	Replace the air vent cover gasket (7).
		The sealing surface of the body (1) or air vent cover (6) is damaged.	Replace the damaged parts.
	From between the bottom cover and cap	The cap (13) is loose.	Retighten the cap (13). *5
		The bottom cover (2) is damaged.	Replace the bottom cover (2).

<b>Problem</b>	<b>Possible cause</b>	<b>Solution</b>
<b>Insufficient condensate is discharged, or no condensate is discharged.</b>	The screen (8) is clogged.	Clean the screen (8).
	Foreign material such as a scale or dirt is stuck to the valve seat (4).	Clean the valve seat (4).
	The air vent screen (17) is clogged.	Clean the air vent screen (17).
	The membrane capsule (thermo element) (14) is damaged.	Replace the membrane capsule (thermo element) (14).
	Wrong installation position	Change the installation so that the main body lies in a horizontal line.
	The steam pressure is over the specified maximum operating pressure.	Lower the pressure or replace the trap with one that has a higher maximum operating pressure.
	Insufficient condensate capacity	Replace the trap with a larger capacity trap.

\*1~5: Refer to the torque tables in Section 5, "Maintenance" to retighten the parts with the correct torque.

## **7 WARRANTY**

---

### **7.1 Warranty period**

The warranty period is 18 months after shipment or 12 months after installation, whichever occurs first.

### **7.2 Details of the warranty**

If the product stops working correctly within the warranty period, we will repair or replace the product free of charge if the cause of the trouble is not one of the following items.

- 1) The precautions described in this manual were not observed.
- 2) User's errors or mistakes such as an inappropriate installation or incorrect handling, or an excessively large impact caused by dropping
- 3) Problems caused by devices or equipment other than MIYAWAKI's, or a disallowed use environment
- 4) When a repair or modification has been performed by anyone other than MIYAWAKI or people who are authorized to make such repairs
- 5) Intrusion of salt or other substances that promote significant rust or corrosion or problems from fluids that contain the same substances
- 6) Consumable parts such as Packing, Gasket, O-ring, Diaphragm, etc.
- 7) Attachment or accumulation of foreign matter in the pipe, such as dust and scale
- 8) Problems from fires, natural disasters, or other force majeure which is not MIYAWAKI's responsibility

### **7.3 Warranty limitation**

The remedy available under the warranty shall not exceed the sales price of the products delivered, for any cause whatsoever.

## 8 SERIAL NUMBER (S. No.) DESIGNATION

The following 4-digit or 9-digit 'S.No.' is displayed on the product.

- For 4-digit display

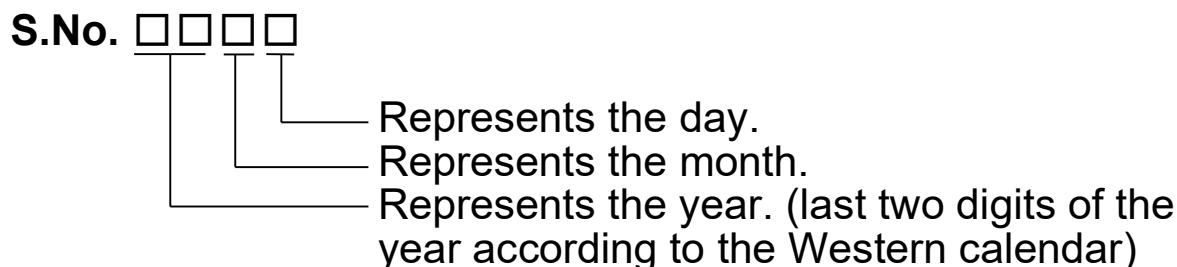

Example of serial number designation  
1 7 1 1 → Jan.1, 2017  
2 9 X M → Oct. 21, 2029

- For 9-digit display

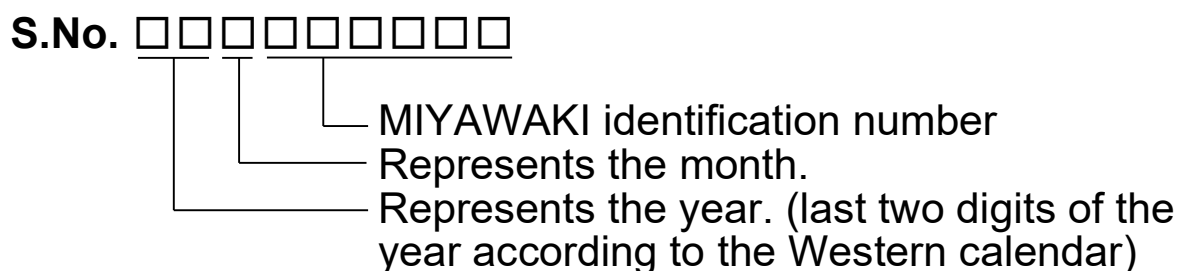

Example of serial number designation  
1 7 1 1 2 C 0 2 0 → Jan., 2017  
2 9 X 0 5 M 0 5 0 → Oct., 2029

### Month designation system

Month	1	2	3	4	5	6	7	8	9	10	11	12
Symbol	1	2	3	4	5	6	7	8	9	X	Y	Z

### Day designation system

Day	1	2	3	4	5	6	7	8	9	10	11	12
Symbol	1	2	3	4	5	6	7	8	9	A	B	C

Day	13	14	15	16	17	18	19	20	21	22	23	24
Symbol	D	E	F	G	H	J	K	L	M	N	O	P

Day	25	26	27	28	29	30	31
Symbol	Q	R	S	T	U	V	W



## 9 GUIDANCE FOR READING SPECIAL PRODUCT NAME

○○○-○○-□

**Special symbol:**  
**The symbol applies only to special products**  
**(Please refer to table 1 for details)**  
 English letter after “-“

**Model symbol:**  
**Product model number**

Table 1 Symbol description

Suffix	Special contents
A	Trap for high-pressure gas installed property
C	Blow valve attached
K	Change of gasket
L	Special face to face dimension
M	Change of parts material
P, T	Change of operating pressure, temperature, condensate capacity, etc
R	Change of screen mesh
V	Change of air vent
X	Other than mentioned above or complex of special contents above

- 
- For any questions about the product that you purchased or about the details in this user's manual, please contact the following.
  - © 2021 MIYAWAKI INC.  
This user's manual may not be reproduced or copied in whole or in part, without the written consent of MIYAWAKI INC.
  - Some special specifications of the product you have, may found to be different from the ones in the user's manual. If you have any question, please contact MIYAWAKI, our local authorized agent, or the place where you purchased.
-



If you need any assistance regarding this manual, please contact MIYAWAKI INC.'s International Sales Dept. or its local representative. By scanning QR Code, you can access inquiry form.



**INTERNATIONAL SALES DEPT.**  
2-1-30, Tagawakita, Yodogawa-ku, Osaka, 532-0021, Japan  
Tel: +81-6-6302-5549  
[www.miyawaki-inc.com/en](http://www.miyawaki-inc.com/en) e-mail: [export@miyawaki-inc.co.jp](mailto:export@miyawaki-inc.co.jp)

EU Importer and Authorized representative:



Birnbaumsmühle 65, 15234 Frankfurt (Oder), Germany  
Tel: +49-335-4007-0097  
[www.miyawaki.de](http://www.miyawaki.de) e-mail: [info@miyawaki.de](mailto:info@miyawaki.de)

China Importer and Authorized representative:



Room 902 ,Building 8, Huaqing Chuangzhi Park, No.3 Qingyan Road, Huishan District, Wuxi  
City Jiangsu Province China  
Tel: +86-510-8359-5125  
[www.miyawaki-inc.com.cn](http://www.miyawaki-inc.com.cn) e-mail: [mywkwest@miyawaki-inc.com.cn](mailto:mywkwest@miyawaki-inc.com.cn)

808131-01 2403

**G30**